

PARKOVI HRVATSKE

**Priručnik  
osnovnih  
grafičkih  
standarda  
znaka  
zaštićenih  
područja u  
Republici  
Hrvatskoj**

4	<b>grupni vizualni identitet</b>	36	vertikalni odnos znak-logotip HR
		37	dimenzije pozitiv
5	<b>osnovni grafički standardi</b>	38	dimenzije negativ
7	verzije znakova i odnosa znak-logotip	39	minimalni zaštitni prostor
		40	apliciranje - akromatske kontinuirane podloge
8	znak	41	apliciranje - kromatske kontinuirane podloge
9	dimenzije	42	apliciranje - diskontinuirane podloge
10	minimalni zaštitni prostor	43	zabrane
11	apliciranje - akromatske kontinuirane podloge		
12	apliciranje - kromatske kontinuirane podloge	44	vertikalni odnos znak-logotip ENG
13	apliciranje - diskontinuirane podloge	45	dimenzije pozitiv
14	zabrane	46	dimenzije negativ
		47	minimalni zaštitni prostor
15	horizontalni odnos znak-logotip HR	48	apliciranje - akromatske kontinuirane podloge
16	dimenzije	49	apliciranje - kromatske kontinuirane podloge
17	minimalni zaštitni prostor	50	apliciranje - diskontinuirane podloge
18	apliciranje - akromatske kontinuirane podloge	51	zabrane
19	apliciranje - kromatske kontinuirane podloge		
20	apliciranje - diskontinuirane podloge	52	vertikalni odnos znak-logotip HR/ENG
21	zabrane	53	dimenzije pozitiv
		54	dimenzije negativ
22	horizontalni odnos znak-logotip ENG	55	minimalni zaštitni prostor
23	dimenzije	56	apliciranje - akromatske kontinuirane podloge
24	minimalni zaštitni prostor	57	apliciranje - kromatske kontinuirane podloge
25	apliciranje - akromatske kontinuirane podloge	58	apliciranje - diskontinuirane podloge
26	apliciranje - kromatske kontinuirane podloge	59	zabrane
27	apliciranje - diskontinuirane podloge		
28	zabrane	60	tipografija vizualnog identiteta
		61	boja vizualnog identiteta
29	horizontalni odnos znak-logotip HR/ENG	62	odnosi znaka 'Parkovi Hrvatske' i znaka pojedinog parka
30	dimenzije	63	horizontalan odnos znakova
31	minimalni zaštitni prostor	64	horizontalan odnos
32	apliciranje - akromatske kontinuirane podloge	66	vertikalni odnos
33	apliciranje - kromatske kontinuirane podloge		
34	apliciranje - diskontinuirane podloge		
35	zabrane		

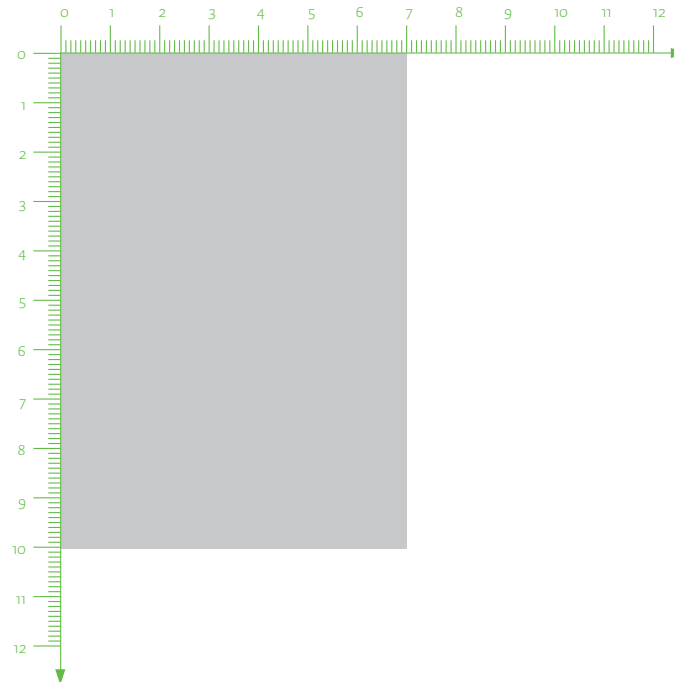

#### **Kotiranje**

Svi predmeti koji se nalaze u priručniku iskotirani su u koordinatnom sustavu sličnom onom koji koriste profesionalni vektorski programi. Sve mjere su izražene u milimetrima. Predmeti su iskotirani tako da im se gornji lijevi kut uvijek nalazi u ishodištu koordinatnog sustava.

#### **Tipografija**

Tipografija upotrebljena na predmetu prikazanom na pojedinoj stranici definirana je u tekstualnom dijelu stranice. Definirana je svojim imenom, rezom, te veličinom i proredom. Veličina i prored izraženi su u točkama i označavaju se ovako:

10/12 pt  
└─ mjerna jedinica  
└─ veličina proreda  
└─ veličina slovnog znaka



# PARKOVI HRVATSKE

Parks  
of Croatia



**KRKA**  
Nacionalni park  
National park



**MLJET**  
Nacionalni park  
National park



**RISNJAK**  
Nacionalni park  
National park



**VELEBIT**  
Park prirode  
Nature park



**BRIJUNI**  
Nacionalni park  
National park



**LASTOVSKO  
OTOČJE** Park prirode  
Nature park



**PAKLENICA**  
Nacionalni park  
National park



**SJEVERNI  
VELEBIT** Nacionalni park  
National park



**VRANSKO  
JEZERO** Park prirode  
Nature park



**KOPAČKI  
RIT** Park prirode  
Nature park



**LONJSKO  
POLJE** Park prirode  
Nature park



**PAPUK**  
Park prirode  
Nature park



**TELAŠĆICA**  
Park prirode  
Nature park



**ŽUMBERAK  
SAMOBORSKO  
GORJE** Park prirode  
Nature park



**KORNATI**  
Nacionalni park  
National park



**MEDVEDNICA**  
Park prirode  
Nature park



**PLITVIČKA  
JEZERA** Nacionalni park  
National park



**UČKA**  
Park prirode  
Nature park

## Grupni vizualni identitet

Potreba za novim grupnim vizualnim identitetom hrvatskih parkova prirode i nacionalnih parkova proizašla je iz strategije zajedničkog nastupanja u medijima i međusobnog podupiranja brandova. Ideja je bila da se svi parkovi skupe pod zajednički brand Parkovi Hrvatske i da se sukladno tome dizajnira novi vizualni identiteti koji će podupirati tu strategiju. Novim sustavom vizualne komunikacije promidžba jednog parka bila bi ujedno i promidžba svih drugih parkova.

Grupni vizualni identitet osmišljen je i dizajniran tako da svaki pojedinačni vizualni identitet funkcionira zasebno, ali su svi izvedeni istim grafičkim jezikom. Taj novouspostavljeni grafički jezik obuhvatio je identitete 19 parkova i krovni vizualni identitet novog branda 'Parkovi Hrvatske'. Znakovi parkova figurativni su motivi koji predstavljaju najveće vrijednosti pojednog parka. Cilj je bio zadržati motive dosadašnjih znakova parkova gdje god je to bilo opravdano i moguće unutar novog sustava.

Novim grupnim vizualnim identitetom parkovi će po prvi puta u Hrvatskoj jasno vizualno komunicirati da su svi dio istog sustava. Iz vizualno iznimno heterogene komunikacije, parkovi će početi homogenu komunikaciju koja će rezultirati neusporedivo većom prepoznatljivošću i novim imidžem.

Iste boje i tipografija, kao glavni elementi vizualnog identiteta, koriste se i na sustavu signalizacije i interpretacije na otvorenom za mrežu parkova Hrvatske te krovnoj interaktivnoj aplikaciji 'Parkovi Hrvatske'.

# Osnovni grafički standardi



### Osnovni grafički standardi

U ovom Priručniku grafičkih standarda predstavljen je sustav apliciranja elemenata vizualnog identiteta.

Kako bi vizualni identitet zaživio, treba se u potpunosti pridržavati pravila iz priručnika. Pravila postoje kako bi se poštovala logika vizualnog identiteta, kako bi svi autori koji će u budućnosti raditi s vizualnim identitetom imali manje problema sa njegovim sustavnim održavanjem.

















Osnovni elementi vizualnog identiteta su: znak, logotip, boja i tipografija te logika apliciranja tih elemenata.





















Osnovni grafički standardi moraju biti sustavno provedeni, dok 'ostala sredstva komunikacije' pružaju mnogo više autorske i kreativne slobode.

! Radi kvalitete i preciznosti reprodukcije odnos znak-logotip i nije dozvoljeno crtati, fotografirati niti iznova konstruirati. Svi odnosi znak-logotip nalaze se u zasebnoj datoteci 'PARKOVI\_HRVATSKE\_LOGO'.

# Verzije znakova i odnosa znak logotip

U ovom priručniku definirani su odnosi znak-logotip na hrvatskom jeziku, na engleskom jeziku i dvojezični. Također, definirani su horizontalni i vertikalni odnosi znak-logotip.

 ↑ AKVAREL ZNAK NEGATIV	 ↑ KOLOR ZNAK NEGATIV	 ↑ CRNO-BIJELI ZNAK NEGATIV
 ↑ HORIZONTALNI AKVAREL ZNAK-LOGOTIP NEGATIV HR	 ↑ HORIZONTALNI KOLOR ZNAK-LOGOTIP NEGATIV HR	 ↑ HORIZONTALNI CRNO-BIJELI ZNAK-LOGOTIP NEGATIV HR
 ↑ HORIZONTALNI AKVAREL ZNAK-LOGOTIP NEGATIV ENG	 ↑ HORIZONTALNI KOLOR ZNAK-LOGOTIP NEGATIV ENG	 ↑ HORIZONTALNI CRNO-BIJELI ZNAK-LOGOTIP NEGATIV ENG
 ↑ HORIZONTALNI AKVAREL ZNAK-LOGOTIP NEGATIV HR/ENG	 ↑ HORIZONTALNI KOLOR ZNAK-LOGOTIP NEGATIV HR/ENG	 ↑ HORIZONTALNI CRNO-BIJELI ZNAK-LOGOTIP NEGATIV HR/ENG
 ↑ VERTIKALNI AKVAREL ZNAK-LOGOTIP NEGATIV HR	 ↑ VERTIKALNI KOLOR ZNAK-LOGOTIP NEGATIV HR	 ↑ VERTIKALNI CRNO-BIJELI ZNAK-LOGOTIP NEGATIV HR
 ↑ VERTIKALNI AKVAREL ZNAK-LOGOTIP NEGATIV ENG	 ↑ VERTIKALNI KOLOR ZNAK-LOGOTIP NEGATIV ENG	 ↑ VERTIKALNI CRNO-BIJELI ZNAK-LOGOTIP NEGATIV ENG
 ↑ VERTIKALNI AKVAREL ZNAK-LOGOTIP NEGATIV HR/ENG	 ↑ VERTIKALNI KOLOR ZNAK-LOGOTIP NEGATIV HR/ENG	 ↑ VERTIKALNI CRNO-BIJELI ZNAK-LOGOTIP NEGATIV HR/ENG

 ↑ AKVAREL ZNAK POZITIV	 ↑ KOLOR ZNAK POZITIV	 ↑ CRNO-BIJELI ZNAK POZITIV
 ↑ HORIZONTALNI AKVAREL ZNAK-LOGOTIP POZITIV HR	 ↑ HORIZONTALNI KOLOR ZNAK-LOGOTIP POZITIV HR	 ↑ HORIZONTALNI CRNO-BIJELI ZNAK-LOGOTIP POZITIV HR
 ↑ HORIZONTALNI AKVAREL ZNAK-LOGOTIP POZITIV ENG	 ↑ HORIZONTALNI KOLOR ZNAK-LOGOTIP POZITIV ENG	 ↑ HORIZONTALNI CRNO-BIJELI ZNAK-LOGOTIP POZITIV ENG
 ↑ HORIZONTALNI AKVAREL ZNAK-LOGOTIP POZITIV HR/ENG	 ↑ HORIZONTALNI KOLOR ZNAK-LOGOTIP POZITIV HR/ENG	 ↑ HORIZONTALNI CRNO-BIJELI ZNAK-LOGOTIP POZITIV HR/ENG
 ↑ VERTIKALNI AKVAREL ZNAK-LOGOTIP POZITIV HR	 ↑ VERTIKALNI KOLOR ZNAK-LOGOTIP POZITIV HR	 ↑ VERTIKALNI CRNO-BIJELI ZNAK-LOGOTIP POZITIV HR
 ↑ VERTIKALNI AKVAREL ZNAK-LOGOTIP POZITIV ENG	 ↑ VERTIKALNI KOLOR ZNAK-LOGOTIP POZITIV ENG	 ↑ VERTIKALNI CRNO-BIJELI ZNAK-LOGOTIP POZITIV ENG
 ↑ VERTIKALNI AKVAREL ZNAK-LOGOTIP POZITIV HR/ENG	 ↑ VERTIKALNI KOLOR ZNAK-LOGOTIP POZITIV HR/ENG	 ↑ VERTIKALNI CRNO-BIJELI ZNAK-LOGOTIP POZITIV HR/ENG

# Znak

## POZITIV

### AKVAREL ZNAK

'Akvarel znak' primarni je znak i preporuča se njegovo korištenje gdje god tehnika reprodukcije i sam dizajn to dopuštaju.

### KOLOR ZNAK

'Kolor znak' sekundarni je znak. Upotrebljava se kada tehnika reprodukcije ne dopušta korištenje 'akvarel znaka'. (npr. sitotisak, oslikavanje, tampon tisak, štik, katiranje itd.)

### CRNO-BIJELI ZNAK

'Crno-bijeli znak' tercijarni je znak. Upotrebljava se isključivo u situacijama kada je nemoguća kolor reprodukcija ili dizajn zahtjeva monokromatski znak. (npr. gravura, žig itd.)



↑  
KOLOR ZNAK



↑  
AKVAREL ZNAK



↑  
CRNO-BIJELI ZNAK

KOLOR ZNAK  
↓



AKVAREL ZNAK  
↓



CRNO-BIJELI ZNAK  
↓



## NEGATIV

### AKVAREL ZNAK

'Akvarel znak' primarni je znak i preporuča se njegovo korištenje gdje god tehnika reprodukcije i sam dizajn to dopuštaju.

### KOLOR ZNAK

'Kolor znak' sekundarni je znak. Upotrebljava se kada tehnika reprodukcije ne dopušta korištenje 'akvarel znaka'. (npr. sitotisak, oslikavanje, tampon tisak, katiranje, štik itd.)

### CRNO-BIJELI ZNAK

'Crno-bijeli znak' tercijarni je znak. Upotrebljava se isključivo u situacijama kada je nemoguća kolor reprodukcija ili dizajn zahtjeva monokromatski znak. (npr. gravura, katiranje itd.)



## ZNAK Dimenzije

Dimenzije znaka određuju se kako bi se stvorio kontinuitet veličina.

### POZITIV

Minimalna veličina znaka je 6,7 × 6,7 mm. Znak se ne smije upotrebljavati manji od te dimenzije.

Za znak koji se upotrebljava u većim dimenzijama od ovdje ilustriranih vrijedi isto progresivno pravilo povećavanja - 500% x, 600% x, 700% x, 800% x, 900% x, 1000% x...

### NEGATIV

Minimalna veličina znaka je 7,5 × 7,5 mm, odnosno 6,7 × 6,7 znaka crno-bijelog negativa.

Znak se ne smije upotrebljavati manji od tih dimenzije.

Za znak koji se upotrebljava u većim dimenzijama od ovdje ilustriranih vrijedi isto progresivno pravilo povećavanja - 500% x, 600% x, 700% x, 800% x, 900% x, 1000% x...



minimalna dimenzija = x  
6,7 × 6,7 mm



150% x



200% x



300% x



400% x



minimalna dimenzija = x  
6,7 × 6,7 mm



150% x



200% x



300% x



400% x



minimalna dimenzija = x  
6,7 × 6,7 mm



150% x



200% x



300% x



400% x



minimalna dimenzija = x  
7,5 × 7,5 mm



150% x



200% x



300% x



400% x



minimalna dimenzija = x  
7,5 × 7,5 mm



150% x



200% x



300% x



400% x



minimalna dimenzija = x  
6,7 × 6,7 mm



150% x



200% x



300% x



400% x

ZNAK

# Minimalni zaštitni prostor

Minimalni zaštitni prostor znaka je prostor oko znaka u kojem se ne smiju nalaziti drugi grafički elementi kako se ne bi narušio integritet samog znaka.

Minimalni zaštitni prostor određen je prema dimenziji  $a$  i prikazan je lijevo (točkasti pravokutnik).

Minimalni zaštitni prostor mijenja se proporcionalno sa dimenzijom samog znaka.

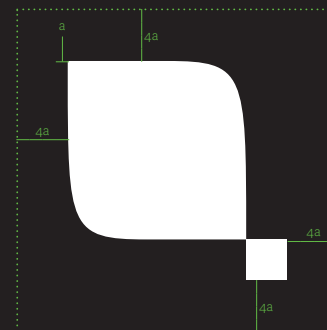
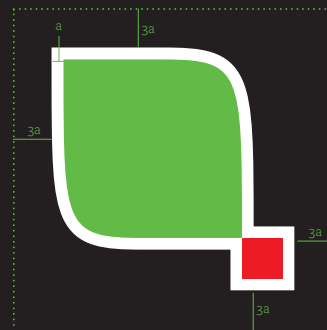
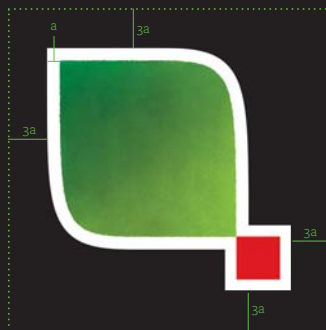
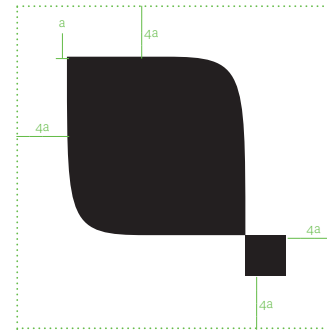
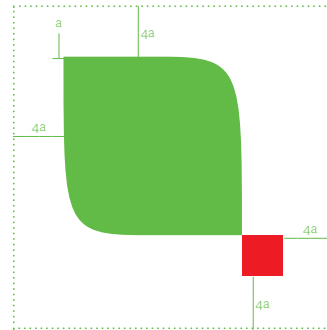
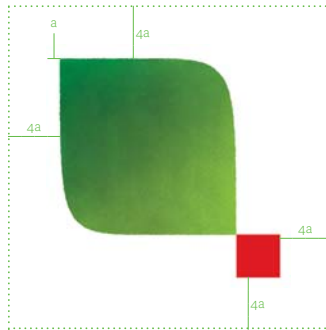

! mjera 'a' vidljiva je u prikazima u negativu

## ZNAK Apliciranje

### AKROMATSKE KONTINUIRANE PODLOGE

Akromatske kontinuirane podloge su ravnomjerne podloge sivog spektra.

Akvarel i kolor znakovi se apliciraju u istom obliku na sve podloge.

Crno-bijeli znak se aplicira u negativu na sve akromatske kontinuirane podloge tamnije ili jednake 50% crne, a u pozitivu na sve akromatske kontinuirane podloge svjetlije od 50% crne.

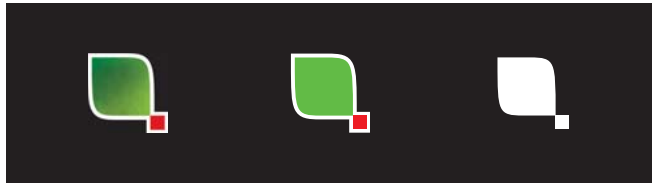

C: 0, M: 0, Y: 0, K: 100



C: 0, M: 0, Y: 0, K: 0

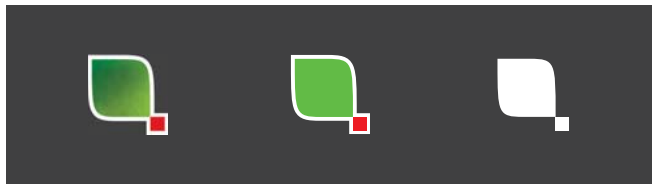

C: 0, M: 0, Y: 0, K: 90

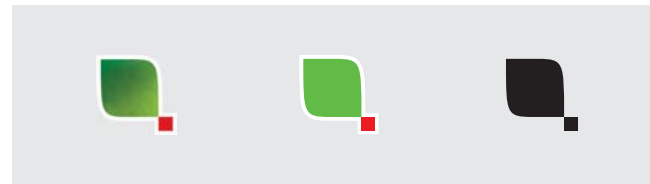

C: 0, M: 0, Y: 0, K: 10

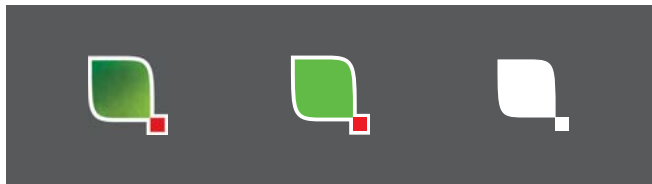

C: 0, M: 0, Y: 0, K: 80

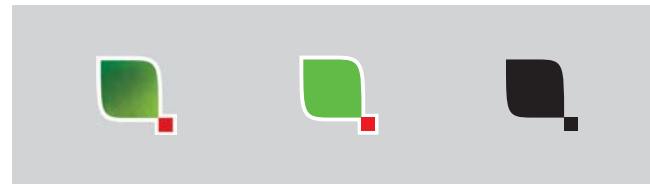

C: 0, M: 0, Y: 0, K: 20

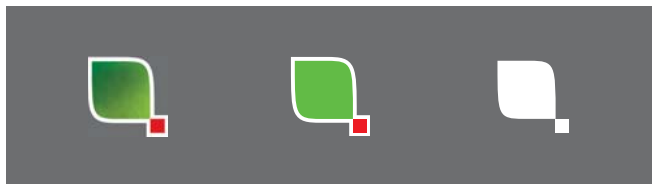

C: 0, M: 0, Y: 0, K: 70

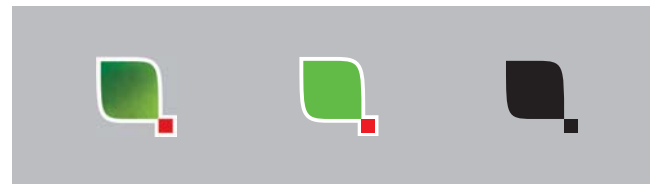

C: 0, M: 0, Y: 0, K: 30

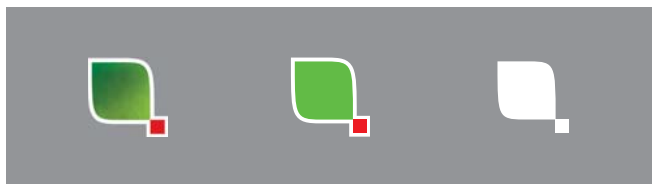

C: 0, M: 0, Y: 0, K: 50

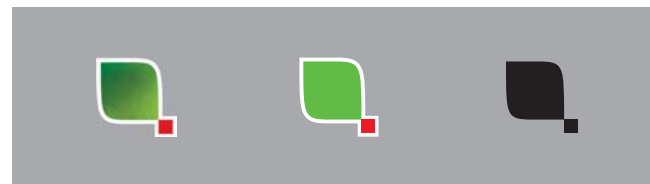

C: 0, M: 0, Y: 0, K: 40

## ZNAK Apliciranje

### KROMATSKE KONTINUIRANE PODLOGE

Kromatske kontinuirane podloge su ravnomjerne obojane podloge.

Akvarelni i kolor znak se apliciraju u istom obliku na sve kromatske kontinuirane podloge.

Crno-bijeli znak se aplicira u negativu na sve kromatske kontinuirane podloge tamnije ili jednake 50% crne.

Crno-bijeli znak se aplicira u pozitivu na sve kromatske kontinuirane podloge svjetlije od 50% crne.

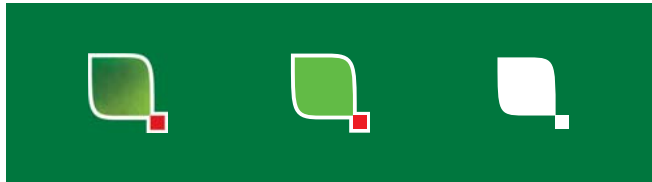

C: 100, M: 0, Y: 100, K: 20, grayscale ekvivalent 61%

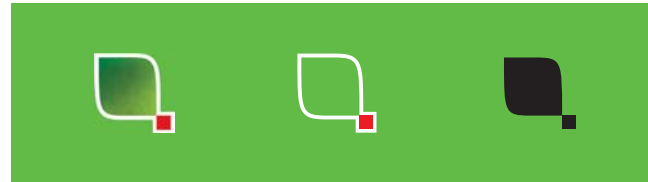

C: 100, M: 0, Y: 100, K: 20, grayscale ekvivalent 30%

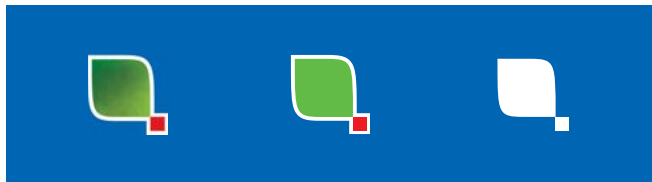

C: 100, M: 60, Y: 0, K: 0, grayscale ekvivalent 65%

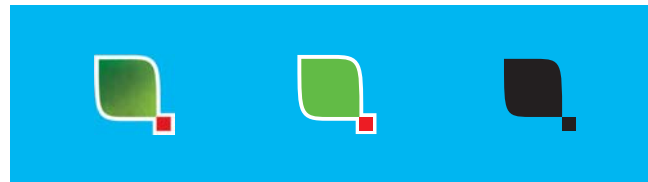

C: 85, M: 0, Y: 0, K: 0, grayscale ekvivalent 25%

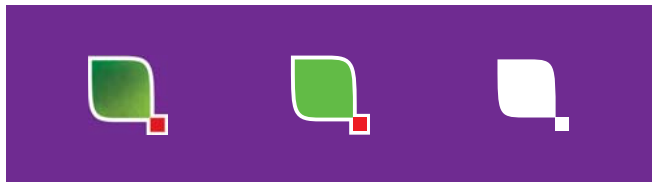

C: 70, M: 100, Y: 0, K: 0, grayscale ekvivalent 80%

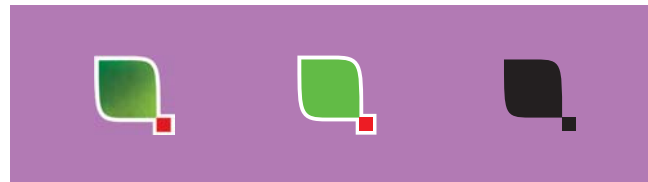

C: 30, M: 60, Y: 0, K: 0, grayscale ekvivalent 44%



C: 0, M: 100, Y: 100, K: 5, grayscale ekvivalent 50%

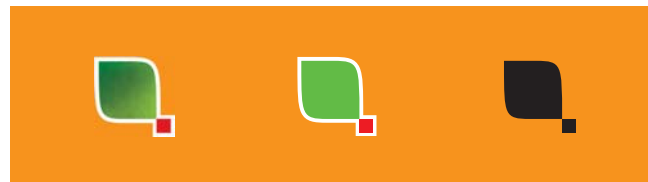

C: 0, M: 50, Y: 100, K: 0, grayscale ekvivalent 40%

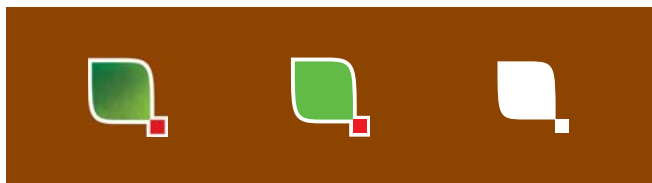

C: 0, M: 65, Y: 100, K: 50, grayscale ekvivalent 99%

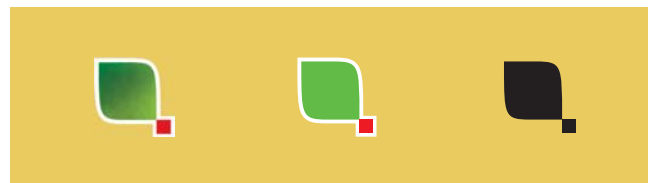

C: 0, M: 10, Y: 70, K: 10, grayscale ekvivalent 24%

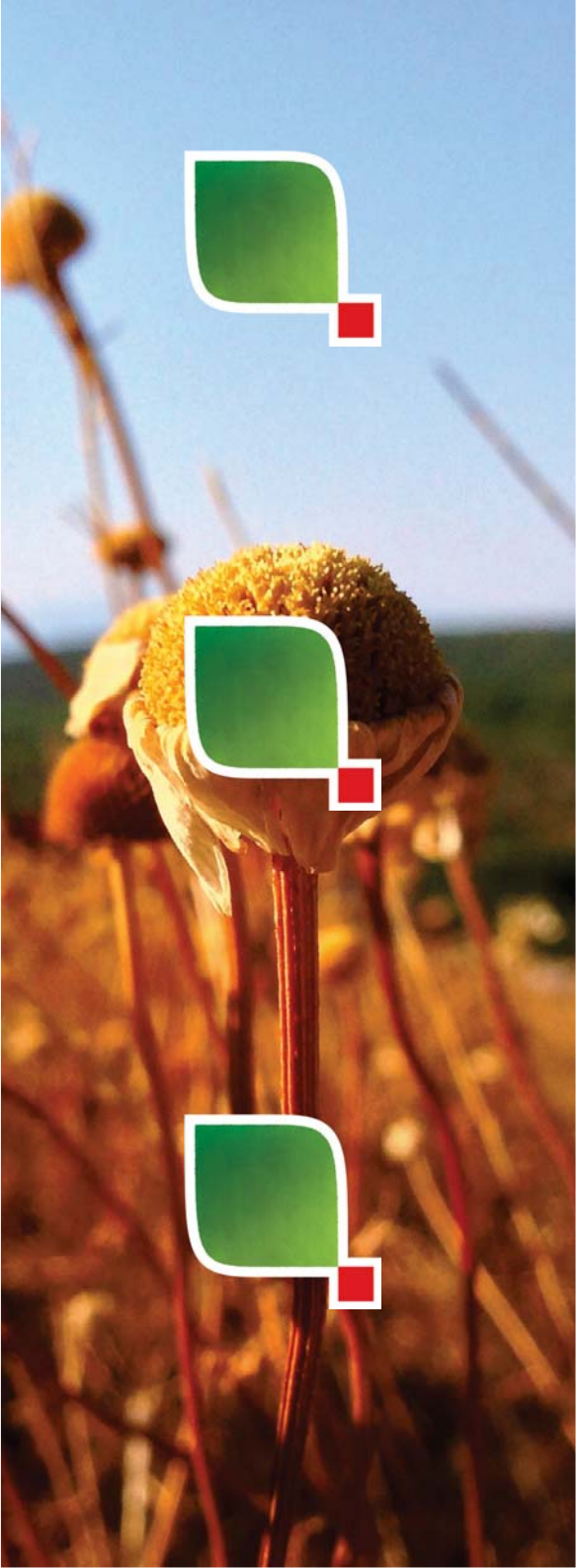

ZNAK  
**Apliciranje**

**DISKONTINUIRANE PODLOGE**

Diskontinuirana podloga je fotografska ili grafička podloga koja nije jednobojna.

Akvarelni i kolor znak se apliciraju u istom obliku na sve diskontinuirane podloge.

Crno-bijeli znak se aplicira u negativu na sve diskontinuirane podloge tamnije ili jednake 50% crne.

Crno-bijeli znak se aplicira u pozitivu na sve diskontinuirane podloge svjetlije od 50% crne.

Treba izbjegavati aplikaciju crno-bijelog znaka na diskontinuiranu podlogu koja je toliko heterogena da znak postaje nečitak.

ZNAK

# Zabrane

**ZABRANJENE APLIKACIJE I MANIPULACIJE**

Znak se nikada ne smije deformirati (sužavati, izduživati, skraćivati, rotirati...). Oblik znaka strogo je propisan, te se svako njegovo narušavanje smatra deformacijom znaka.

Dozvoljena apliciranja znaka na razne pozadine ovise o njegovoj čitkosti i nenarušavanju vizualne komunikativnosti.

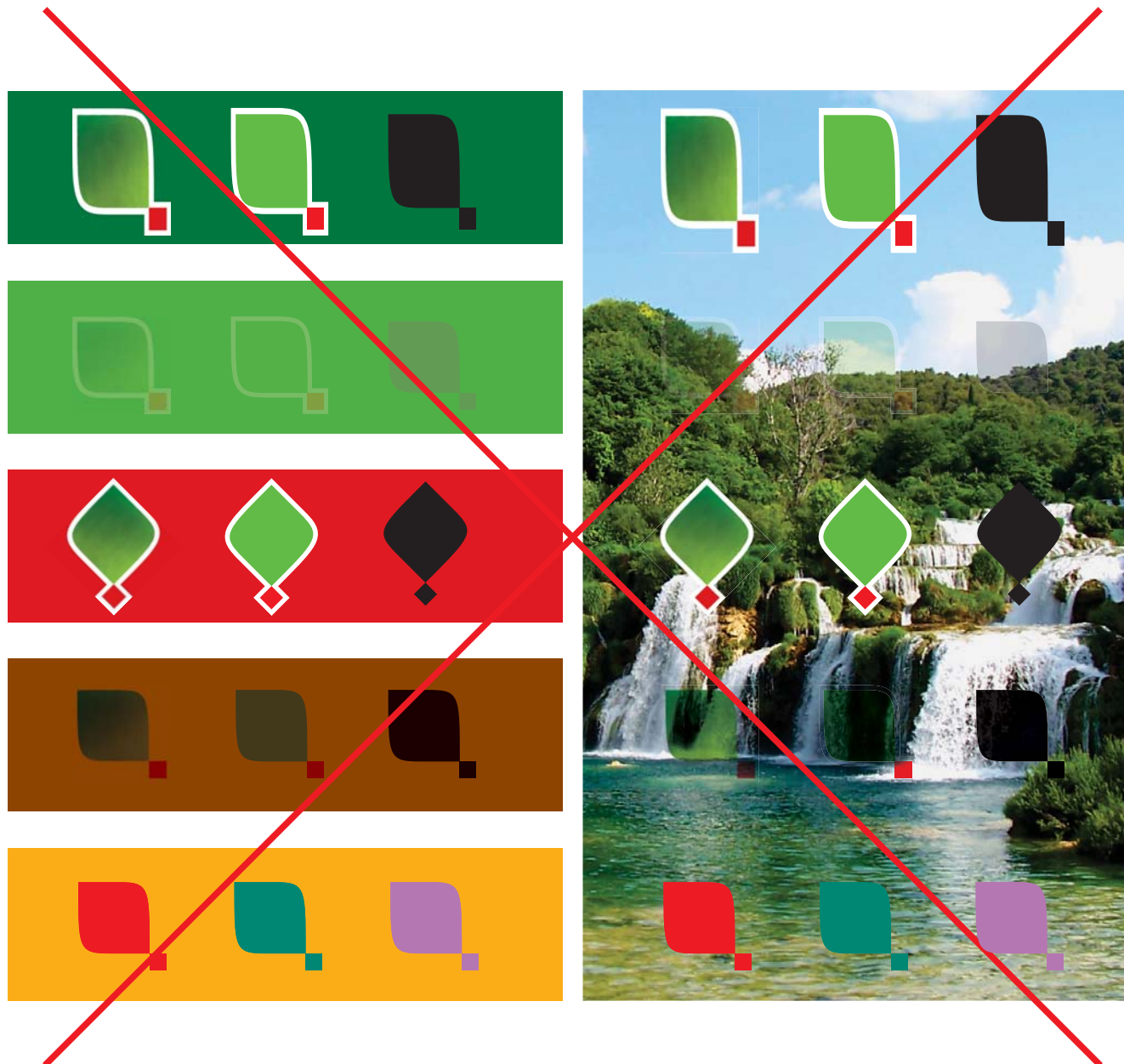



**PARKOVI  
HRVATSKE**



AKVAREL ZNAK-LOGOTIP HORIZONTALNI NEGATIV



**PARKOVI  
HRVATSKE**



KOLOR ZNAK-LOGOTIP HORIZONTALNI NEGATIV



**PARKOVI  
HRVATSKE**



CRNO-BIJELI ZNAK-LOGOTIP HORIZONTALNI NEGATIV



**PARKOVI  
HRVATSKE**



AKVAREL ZNAK-LOGOTIP HORIZONTALNI POZITIV



**PARKOVI  
HRVATSKE**



KOLOR ZNAK-LOGOTIP HORIZONTALNI POZITIV



**PARKOVI  
HRVATSKE**



CRNO-BIJELI ZNAK-LOGOTIP HORIZONTALNI POZITIV

## PARKOVI HRVATSKE

PRIRUČNIK OSNOVNIH GRAFIČKIH STANDARDA

# Horizontalni odnos znak- logotip HR

### NEGATIV

#### AKVAREL ZNAK-LOGOTIP HORIZONTALNI

'Akvarel znak-logotip horizontalni' primarni je odnos znak-logotip i preporuča se njegovo korištenje gdje god tehnika reprodukcije i sam dizajn to dopuštaju.

#### KOLOR ZNAK-LOGOTIP HORIZONTALNI

'Kolor znak-logotip horizontalni' sekundarni je odnos znak-logotip. Upotrebljava se kada tehnika reprodukcije ne dopušta korištenje 'akvarel znak-logotip horizontalni'. (npr. sitotisak, oslikavanje, tampon tisak, katanje, štik itd.)

#### CRNO-BIJELI ZNAK-LOGOTIP HORIZONTALNI

'Crno-bijeli znak-logotip horizontalni' tercijarni je odnos znak-logotip. Upotrebljava se isključivo u situacijama kada je nemoguća kolor reprodukcija ili dizajn zahtjeva monokromatski znak-logotip. (npr. gravura, katanje itd.)

### POZITIV

#### AKVAREL ZNAK-LOGOTIP HORIZONTALNI

'Akvarel znak-logotip horizontalni' primarni je odnos znak-logotip i preporuča se njegovo korištenje gdje god tehnika reprodukcije i sam dizajn to dopuštaju.

#### KOLOR ZNAK-LOGOTIP HORIZONTALNI

'Kolor znak-logotip horizontalni' sekundarni je odnos znak-logotip. Upotrebljava se kada tehnika reprodukcije ne dopušta korištenje 'akvarel znak-logotip horizontalni'. (npr. sitotisak, oslikavanje, tampon tisak, katanje, štik itd.)

#### CRNO-BIJELI ZNAK-LOGOTIP HORIZONTALNI

'Crno-bijeli znak-logotip horizontalni' tercijarni je odnos znak-logotip. Upotrebljava se isključivo u situacijama kada je nemoguća kolor reprodukcija ili dizajn zahtjeva monokromatski znak-logotip. (npr. gravura, žig itd.)

ZNAK-LOGOTIP HORIZONTALNI HR  
**Dimenzije**

Dimenzije odnosa znak-logotip određuju se kako bi se stvorio kontinuitet veličina.

**POZITIV**

Minimalna veličina horizontalnog odnosa znak-logotip je 34 × 12 mm. Horizontalni znak-logotip se ne smije upotrebljavati manji od te dimenzije.

Za znak-logotip koji se upotrebljava u većim dimenzijama od ovdje ilustriranih vrijedi isto progresivno pravilo povećavanja - 300% x, 400% x, 500% x, 600% x, 700% x, 800% x, 900% x...



**NEGATIV**

Minimalna veličina horizontalnog odnosa znak-logotip je 35 × 13 mm. Horizontalni znak-logotip se ne smije upotrebljavati manji od te dimenzije.

Za znak-logotip koji se upotrebljava u većim dimenzijama od ovdje ilustriranih vrijedi isto progresivno pravilo povećavanja - 300% x, 400% x, 500% x, 600% x, 700% x, 800% x, 900% x...



# Minimalni zaštitni prostor

Minimalni zaštitni prostor odnosa znak-logotip je prostor oko znak-logotipa u kojem se ne smiju nalaziti drugi grafički elementi kako se ne bi narušio integritet samog znaka.

Minimalni prostor određen je prema dimenziji  $a$  i prikazan je lijevo (točkasti pravokutnik).

Minimalni prostor mjenja se proporcionalno sa dimenzijom samog odnosa znak-logotip.



! mjera 'a' vidljiva je u prikazima u negativu

## ZNAK-LOGOTIP HORIZONTALNI HR Apliciranje

### AKROMATSKE KONTINUIRANE PODLOGE

Akromatske kontinuirane podloge su  
ravnomjerne podloge sivog spektra.

Znak-logotip se aplicira u negativu na sve  
akromatske kontinuirane podloge tamnije ili  
jednake 50% crne.

Znak-logotip se aplicira u pozitivu na sve  
akromatske kontinuirane podloge svjetlije od  
50% crne.



C: 0, M: 0, Y: 0, K: 100



C: 0, M: 0, Y: 0, K: 0



C: 0, M: 0, Y: 0, K: 90



C: 0, M: 0, Y: 0, K: 10



C: 0, M: 0, Y: 0, K: 80



C: 0, M: 0, Y: 0, K: 20



C: 0, M: 0, Y: 0, K: 70



C: 0, M: 0, Y: 0, K: 30



C: 0, M: 0, Y: 0, K: 50

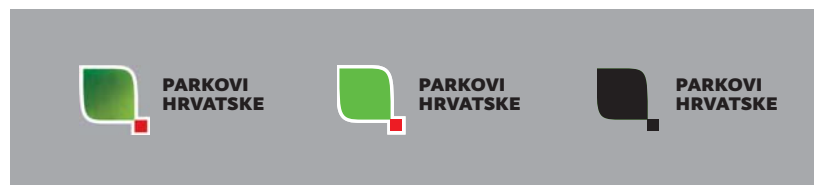

C: 0, M: 0, Y: 0, K: 40

## ZNAK-LOGOTIP HORIZONTALNI HR Apliciranje

**KROMATSKE KONTINUIRANE PODLOGE**  
Kromatske kontinuirane podloge su ravnomjerne obojane podloge.

Znak-logotip se aplicira u negativu na sve kromatske kontinuirane podloge tamnije ili jednake 50% crne.

Znak-logotip se aplicira u pozitivu na sve kromatske kontinuirane podloge svjetlije od 50% crne.



C: 100, M: 0, Y: 100, K: 20, grayscale ekvivalent 61%



C: 100, M: 0, Y: 100, K: 20, grayscale ekvivalent 30%



C: 100, M: 60, Y: 0, K: 0, grayscale ekvivalent 65%



C: 85, M: 0, Y: 0, K: 0, grayscale ekvivalent 25%

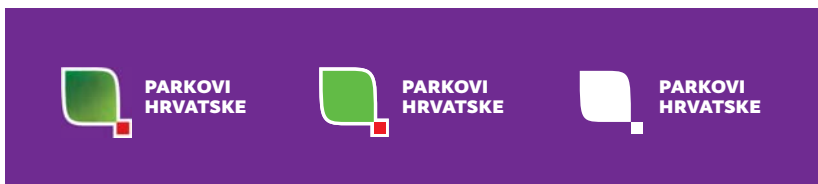

C: 70, M: 100, Y: 0, K: 0, grayscale ekvivalent 80%



C: 30, M: 60, Y: 0, K: 0, grayscale ekvivalent 44%



C: 0, M: 100, Y: 100, K: 5, grayscale ekvivalent 50%



C: 0, M: 50, Y: 100, K: 0, grayscale ekvivalent 40%



C: 0, M: 65, Y: 100, K: 50, grayscale ekvivalent 99%



C: 0, M: 10, Y: 70, K: 10, grayscale ekvivalent 24%



## Apliciranje

### **DISKONTINUIRANE PODLOGE**

Diskontinuirana podloga je fotografska ili grafička podloga koja nije jednobojna.

Akvarel i kolor znak-logotip aplicira se u negativu na sve diskontinuirane podloge kojima je srednja svjetlina tamnija ili jednaka 50% crne.

Akvarel i kolor znak-logotip aplicira se u pozitivu na sve diskontinuirane podloge kojima je srednja svjetlina svijetlija od 50% crne.

Treba izbjegavati aplikaciju znaka-logotipa na diskontinuiranu podlogu koja je toliko heterogena da logotip (i pozitiv i negativ verzija) postaje nečitak.

## ZNAK-LOGOTIP HORIZONTALNI HR Zabrane

**ZABRANJENE APLIKACIJE I MANIPULACIJE**  
Odnos znak-logotip se nikada ne smije deformirati (sužavati, izduživati, skraćivati, rotirati...). Odnos znak-logotip strogo je propisan, te se svako njegovo narušavanje smatra deformacijom.

Dozvoljena apliciranja znaka-logotipa na razne pozadine ovise o njegovoj čitkosti i nenarušavanju vizualne komunikativnosti.

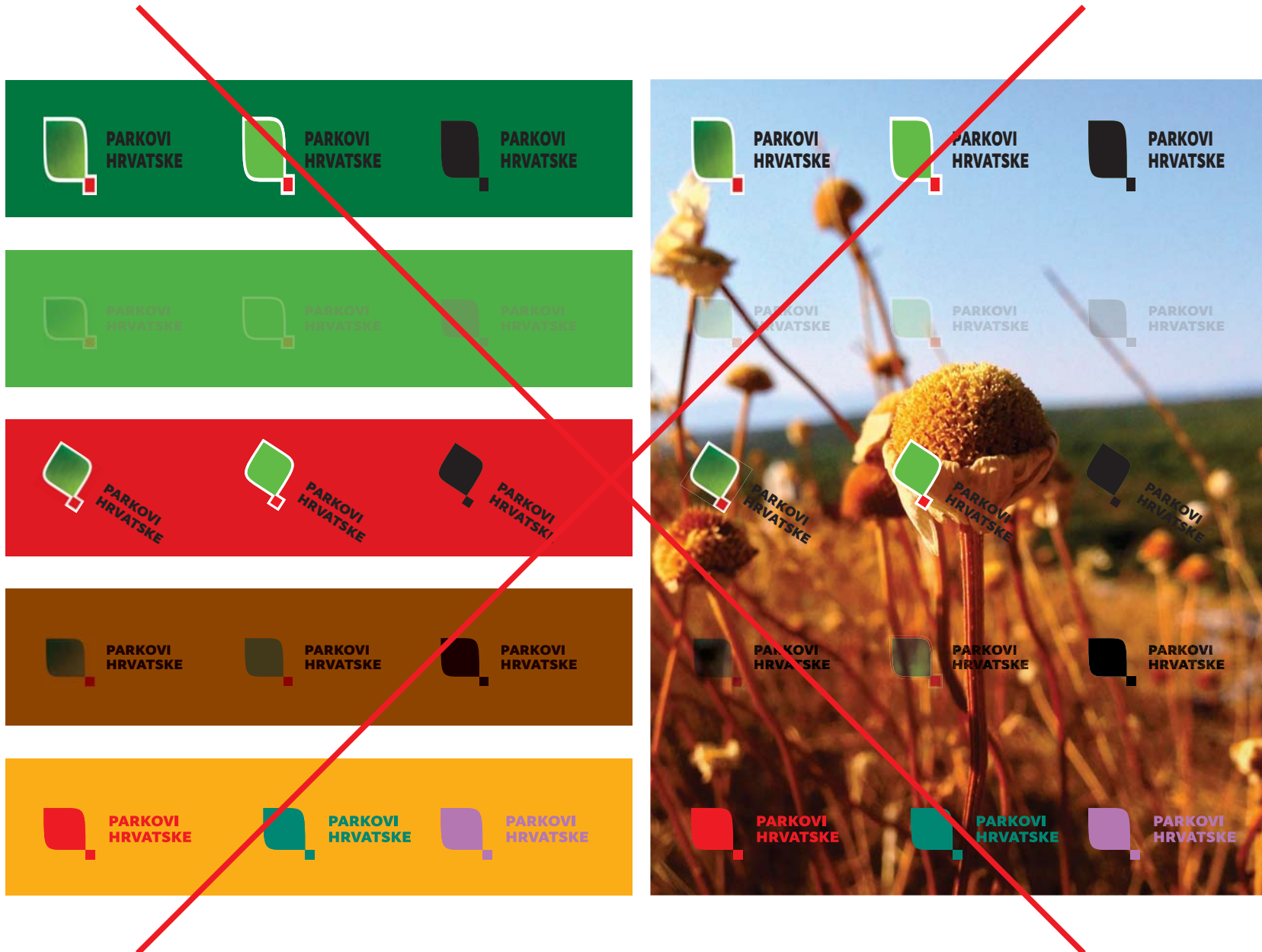



**PARKS OF  
CROATIA**



AKVAREL ZNAK-LOGOTIP HORIZONTALNI NEGATIV



**PARKS OF  
CROATIA**



KOLOR ZNAK-LOGOTIP HORIZONTALNI NEGATIV



**PARKS OF  
CROATIA**



CRNO-BIJELI ZNAK-LOGOTIP HORIZONTALNI NEGATIV



**PARKS OF  
CROATIA**



AKVAREL ZNAK-LOGOTIP HORIZONTALNI POZITIV



**PARKS OF  
CROATIA**



KOLOR ZNAK-LOGOTIP HORIZONTALNI POZITIV



**PARKS OF  
CROATIA**



CRNO-BIJELI ZNAK-LOGOTIP HORIZONTALNI POZITIV

## Horizontalni odnos znak- logotip ENG

### NEGATIV

#### AKVAREL ZNAK-LOGOTIP HORIZONTALNI

'Akvarel znak-logotip horizontalni' primarni je odnos znak-logotip i preporuča se njegovo korištenje gdje god tehnika reprodukcije i sam dizajn to dopuštaju.

#### KOLOR ZNAK-LOGOTIP HORIZONTALNI

'Kolor znak-logotip horizontalni' sekundarni je odnos znak-logotip. Upotrebljava se kada tehnika reprodukcije ne dopušta korištenje 'akvarel znak-logotip horizontalni'. (npr. sitotisak, oslikavanje, tampon tisak, katanje, štik itd.)

#### CRNO-BIJELI ZNAK-LOGOTIP HORIZONTALNI

'Crno-bijeli znak-logotip horizontalni' tercijarni je odnos znak-logotip. Upotrebljava se isključivo u situacijama kada je nemoguća kolor reprodukcija ili dizajn zahtjeva monokromatski znak-logotip. (npr. gravura, katanje itd.)

### POZITIV

#### AKVAREL ZNAK-LOGOTIP HORIZONTALNI

'Akvarel znak-logotip horizontalni' primarni je odnos znak-logotip i preporuča se njegovo korištenje gdje god tehnika reprodukcije i sam dizajn to dopuštaju.

#### KOLOR ZNAK-LOGOTIP HORIZONTALNI

'Kolor znak-logotip horizontalni' sekundarni je odnos znak-logotip. Upotrebljava se kada tehnika reprodukcije ne dopušta korištenje 'akvarel znak-logotip horizontalni'. (npr. sitotisak, oslikavanje, tampon tisak, katanje, štik itd.)

#### CRNO-BIJELI ZNAK-LOGOTIP HORIZONTALNI

'Crno-bijeli znak-logotip horizontalni' tercijarni je odnos znak-logotip. Upotrebljava se isključivo u situacijama kada je nemoguća kolor reprodukcija ili dizajn zahtjeva monokromatski znak-logotip. (npr. gravura, žig itd.)

ZNAK-LOGOTIP HORIZONTALNI ENG  
**Dimenzije**

Dimenzije odnosa znak-logotip određuju se kako bi se stvorio kontinuitet veličina.

**POZITIV**

Minimalna veličina horizontalnog odnosa znak-logotip je 33 x 12 mm. Horizontalni znak-logotip se ne smije upotrebljavati manji od te dimenzije.

Za znak-logotip koji se upotrebljava u većim dimenzijama od ovdje ilustriranih vrijedi isto progresivno pravilo povećavanja - 300% x, 400% x, 500% x, 600% x, 700% x, 800% x, 900% x...

**NEGATIV**

Minimalna veličina horizontalnog odnosa znak-logotip je 34 x 13 mm. Horizontalni znak-logotip se ne smije upotrebljavati manji od te dimenzije.

Za znak-logotip koji se upotrebljava u većim dimenzijama od ovdje ilustriranih vrijedi isto progresivno pravilo povećavanja - 300% x, 400% x, 500% x, 600% x, 700% x, 800% x, 900% x...



# Minimalni zaštitni prostor

Minimalni zaštitni prostor odnosa znak-logotip je prostor oko znak-logotipa u kojem se ne smiju nalaziti drugi grafički elementi kako se ne bi narušio integritet samog znaka.

Minimalni prostor određen je prema dimenziji  $a$  i prikazan je lijevo (točkasti pravokutnik).

Minimalni prostor mjenja se proporcionalno sa dimenzijom samog odnosa znak-logotip.

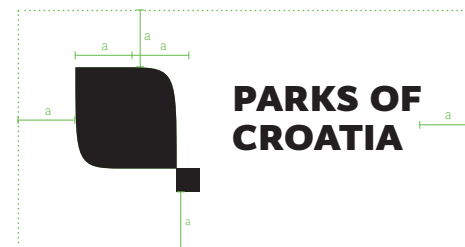
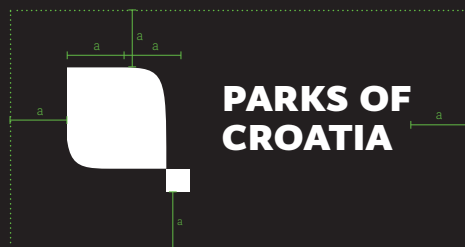
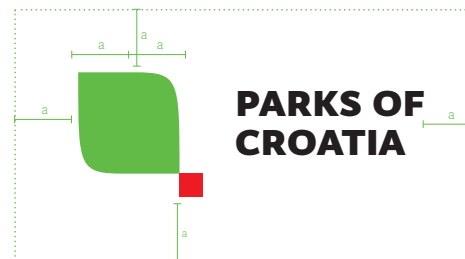
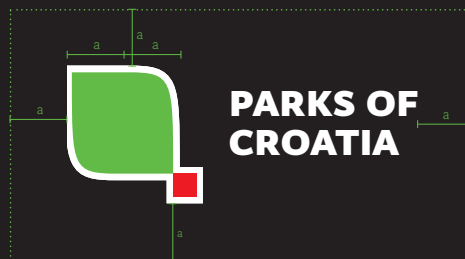
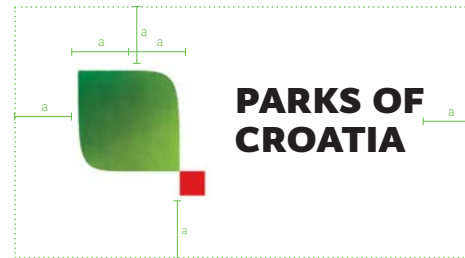
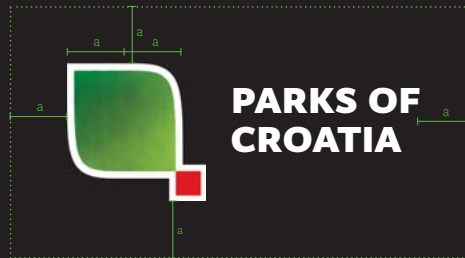

! mjera 'a' vidljiva je u prikazima u negativu



## ZNAK-LOGOTIP HORIZONTALNI ENG Apliciranje

### AKROMATSKE KONTINUIRANE PODLOGE

Akromatske kontinuirane podloge su  
ravnomyjerne podloge sivog spektra.

Znak-logotip se aplicira u negativu na sve  
akromatske kontinuirane podloge tamnije ili  
jednake 50% crne.

Znak-logotip se aplicira u pozitivu na sve  
akromatske kontinuirane podloge svjetlije od  
50% crne.



C: 0, M: 0, Y: 0, K: 100



C: 0, M: 0, Y: 0, K: 0



C: 0, M: 0, Y: 0, K: 90



C: 0, M: 0, Y: 0, K: 10



C: 0, M: 0, Y: 0, K: 80



C: 0, M: 0, Y: 0, K: 20



C: 0, M: 0, Y: 0, K: 70



C: 0, M: 0, Y: 0, K: 30



C: 0, M: 0, Y: 0, K: 50



C: 0, M: 0, Y: 0, K: 40

# Apliciranje

## KROMATSKE KONTINUIRANE PODLOGE

Kromatske kontinuirane podloge su ravnomjerne obojane podloge.

Znak-logotip se aplicira u negativu na sve kromatske kontinuirane podloge tamnije ili jednake 50% crne.

Znak-logotip se aplicira u pozitivu na sve kromatske kontinuirane podloge svjetlije od 50% crne.



C: 100, M: 0, Y: 100, K: 20, grayscale ekvivalent 61%



C: 100, M: 0, Y: 100, K: 20, grayscale ekvivalent 30%



C: 100, M: 60, Y: 0, K: 0, grayscale ekvivalent 65%

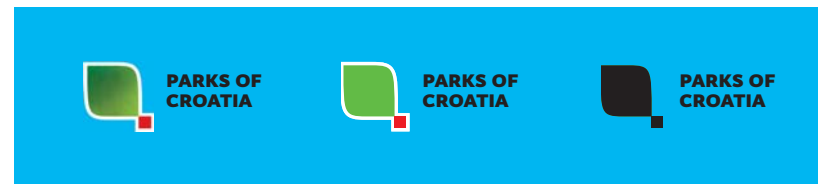

C: 85, M: 0, Y: 0, K: 0, grayscale ekvivalent 25%



C: 70, M: 100, Y: 0, K: 0, grayscale ekvivalent 80%

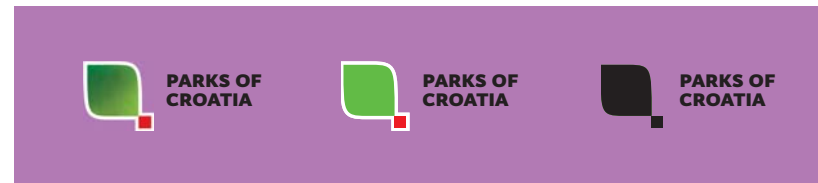

C: 30, M: 60, Y: 0, K: 0, grayscale ekvivalent 44%



C: 0, M: 100, Y: 100, K: 5, grayscale ekvivalent 50%

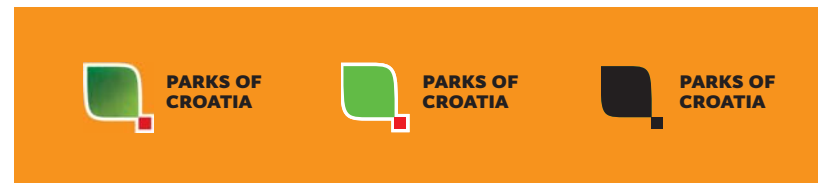

C: 0, M: 50, Y: 100, K: 0, grayscale ekvivalent 40%



C: 0, M: 65, Y: 100, K: 50, grayscale ekvivalent 99%

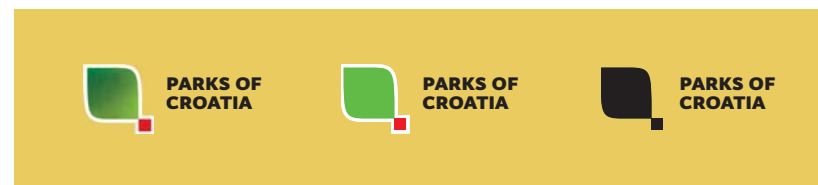

C: 0, M: 10, Y: 70, K: 10, grayscale ekvivalent 24%



**PARKS OF  
CROATIA**



**PARKS OF  
CROATIA**



**PARKS OF  
CROATIA**



**PARKS OF  
CROATIA**



**PARKS OF  
CROATIA**



**PARKS OF  
CROATIA**



**PARKS OF  
CROATIA**



**PARKS OF  
CROATIA**



**PARKS OF  
CROATIA**

# Apliciranje

## DISKONTINUIRANE PODLOGE

Diskontinuirana podloga je fotografska ili grafička podloga koja nije jednobojna.

Akvarel i kolor znak-logotip aplicira se u negativu na sve diskontinuirane podloge kojima je srednja svjetlina tamnija ili jednaka 50% crne.

Akvarel i kolor znak-logotip aplicira se u pozitivu na sve diskontinuirane podloge kojima je srednja svjetlina svijetlija od 50% crne.

Treba izbjegavati aplikaciju znaka-logotipa na diskontinuiranu podlogu koja je toliko heterogena da logotip (i pozitiv i negativ verzija) postaje nečitak.

ZNAK-LOGOTIP HORIZONTALNI ENG

# Zabrane

**ZABRANJENE APLIKACIJE I MANIPULACIJE**

Odnos znak-logotip se nikada ne smije deformirati (sužavati, izduživati, skraćivati, rotirati...). Odnos znak-logotip strogo je propisan, te se svako njegovo narušavanje smatra deformacijom.

Dozvoljena apliciranja znaka-logotipa na razne pozadine ovise o njegovoj čitkosti i nenarušavanju vizualne komunikativnosti.





**PARKOVI** Parks  
of Croatia  
**HRVATSKE**

↑  
AKVAREL ZNAK-LOGOTIP HORIZONTALNI NEGATIV



**PARKOVI** Parks  
of Croatia  
**HRVATSKE**

↑  
KOLOR ZNAK-LOGOTIP HORIZONTALNI NEGATIV



**PARKOVI** Parks  
of Croatia  
**HRVATSKE**

↑  
CRNO-BIJELI ZNAK-LOGOTIP HORIZONTALNI NEGATIV



**PARKOVI** Parks  
of Croatia  
**HRVATSKE**

↑  
AKVAREL ZNAK-LOGOTIP HORIZONTALNI POZITIV



**PARKOVI** Parks  
of Croatia  
**HRVATSKE**

↑  
KOLOR ZNAK-LOGOTIP HORIZONTALNI POZITIV



**PARKOVI** Parks  
of Croatia  
**HRVATSKE**

↑  
CRNO-BIJELI ZNAK-LOGOTIP HORIZONTALNI POZITIV

## Horizontalni odnos znak- logotip HR/ENG

**NEGATIV**  
**AKVAREL ZNAK-LOGOTIP HORIZONTALNI**  
'Akvel znak-logotip horizontalni' primarni je odnos znak-logotip i preporuča se njegovo korištenje gdje god tehnika reprodukcije i sam dizajn to dopuštaju.

**KOLOR ZNAK-LOGOTIP HORIZONTALNI**  
'Kolor znak-logotip horizontalni' sekundarni je odnos znak-logotip. Upotrebljava se kada tehnika reprodukcije ne dopušta korištenje 'akvel znak-logotip horizontalni'. (npr. sitotisak, oslikavanje, tampon tisak, katiranje, štik itd.)

**CRNO-BIJELI ZNAK-LOGOTIP HORIZONTALNI**  
'Crno-bijeli znak-logotip horizontalni' tercijarni je odnos znak-logotip. Upotrebljava se isključivo u situacijama kada je nemoguća kolor reprodukcija ili dizajn zahtjeva monokromatski znak-logotip. (npr. gravura, katiranje itd.)

**POZITIV**  
**AKVAREL ZNAK-LOGOTIP HORIZONTALNI**  
'Akvel znak-logotip horizontalni' primarni je odnos znak-logotip i preporuča se njegovo korištenje gdje god tehnika reprodukcije i sam dizajn to dopuštaju.

**KOLOR ZNAK-LOGOTIP HORIZONTALNI**  
'Kolor znak-logotip horizontalni' sekundarni je odnos znak-logotip. Upotrebljava se kada tehnika reprodukcije ne dopušta korištenje 'akvel znak-logotip horizontalni'. (npr. sitotisak, oslikavanje, tampon tisak, katiranje, štik itd.)

**CRNO-BIJELI ZNAK-LOGOTIP HORIZONTALNI**  
'Crno-bijeli znak-logotip horizontalni' tercijarni je odnos znak-logotip. Upotrebljava se isključivo u situacijama kada je nemoguća kolor reprodukcija ili dizajn zahtjeva monokromatski znak-logotip. (npr. gravura, žig itd.)

ZNAK-LOGOTIP HORIZONTALNI HR/ENG

# Dimenzije

Dimenzije odnosa znak-logotip određuju se kako bi se stvorio kontinuitet veličina.

**POZITIV**

Minimalna veličina horizontalnog odnosa znak-logotip je 38 x 12 mm. Horizontalni znak-logotip se ne smije upotrebljavati manji od te dimenzije.

Za znak-logotip koji se upotrebljava u većim dimenzijama od ovdje ilustriranih vrijedi isto progresivno pravilo povećavanja - 300% x, 400% x, 500% x, 600% x, 700% x, 800% x, 900% x...



**NEGATIV**

Minimalna veličina horizontalnog odnosa znak-logotip je 38 x 13 mm. Horizontalni znak-logotip se ne smije upotrebljavati manji od te dimenzije.

Za znak-logotip koji se upotrebljava u većim dimenzijama od ovdje ilustriranih vrijedi isto progresivno pravilo povećavanja - 300% x, 400% x, 500% x, 600% x, 700% x, 800% x, 900% x...

# Minimalni zaštitni prostor

Minimalni zaštitni prostor odnosa znak-logotip je prostor oko znak-logotipa u kojem se ne smiju nalaziti drugi grafički elementi kako se ne bi narušio integritet samog znaka.

Minimalni prostor određen je prema dimenziji *a* i prikazan je lijevo (točkasti pravokutnik).

Minimalni prostor mjenja se proporcionalno sa dimenzijom samog odnosa znak-logotip.



! mjera 'a' vidljiva je u prikazima u negativu

## ZNAK-LOGOTIP HORIZONTALNI HR/ENG Apliciranje

### AKROMATSKE KONTINUIRANE PODLOGE

Akromatske kontinuirane podloge su  
ravnomyjerne podloge sivog spektra.

Znak-logotip se aplicira u negativu na sve  
akromatske kontinuirane podloge tamnije ili  
jednake 50% crne.

Znak-logotip se aplicira u pozitivu na sve  
akromatske kontinuirane podloge svjetlije od  
50% crne.



C: 0, M: 0, Y: 0, K: 100



C: 0, M: 0, Y: 0, K: 0



C: 0, M: 0, Y: 0, K: 90



C: 0, M: 0, Y: 0, K: 10



C: 0, M: 0, Y: 0, K: 80



C: 0, M: 0, Y: 0, K: 20



C: 0, M: 0, Y: 0, K: 70



C: 0, M: 0, Y: 0, K: 30



C: 0, M: 0, Y: 0, K: 50



C: 0, M: 0, Y: 0, K: 40



ZNAK-LOGOTIP HORIZONTALNI HR/ENG

# Apliciranje

KROMATSKE KONTINUIRANE PODLOGE

Kromatske kontinuirane podloge su ravnomjerne obojane podloge.

Znak-logotip se aplicira u negativu na sve kromatske kontinuirane podloge tamnije ili jednake 50% crne.

Znak-logotip se aplicira u pozitivu na sve kromatske kontinuirane podloge svjetlije od 50% crne.



C: 100, M: 0, Y: 100, K: 20, grayscale ekvivalent 61%



C: 100, M: 0, Y: 100, K: 20, grayscale ekvivalent 30%



C: 100, M: 60, Y: 0, K: 0, grayscale ekvivalent 65%



C: 85, M: 0, Y: 0, K: 0, grayscale ekvivalent 25%



C: 70, M: 100, Y: 0, K: 0, grayscale ekvivalent 80%



C: 30, M: 60, Y: 0, K: 0, grayscale ekvivalent 44%



C: 0, M: 100, Y: 100, K: 5, grayscale ekvivalent 50%



C: 0, M: 50, Y: 100, K: 0, grayscale ekvivalent 40%



C: 0, M: 65, Y: 100, K: 50, grayscale ekvivalent 99%



C: 0, M: 10, Y: 70, K: 10, grayscale ekvivalent 24%



**PARKOVI HRVATSKE**  
PRIRUČNIK OSNOVNIH GRAFIČKIH STANDARDA

**ZNAK-LOGOTIP HORIZONTALNI HR/ENG**

## Apliciranje

### DISKONTINUIRANE PODLOGE

Diskontinuirana podloga je fotografska ili grafička podloga koja nije jednobojna.

Akvarel i kolor znak-logotip aplicira se u negativu na sve diskontinuirane podloge kojima je srednja svjetlina tamnija ili jednaka 50% crne.

Akvarel i kolor znak-logotip aplicira se u pozitivu na sve diskontinuirane podloge kojima je srednja svjetlina svjetlija od 50% crne.

Treba izbjegavati aplikaciju znaka-logotipa na diskontinuiranu podlogu koja je toliko heterogena da logotip (i pozitiv i negativ verzija) postaje nečitak.

ZNAK-LOGOTIP HORIZONTALNI HR/RNG

# Zabrane

ZABRANJENE APLIKACIJE I MANIPULACIJE

Odnos znak-logotip se nikada ne smije deformirati (sužavati, izduživati, skraćivati, rotirati...). Odnos znak-logotip strogo je propisan, te se svako njegovo narušavanje smatra deformacijom.

Dozvoljena apliciranja znaka-logotipa na razne pozadine ovise o njegovoj čitkosti i nenarušavanju vizualne komunikativnosti.





↑  
AKVAREL ZNAK-LOGOTIP VERTIKALNI NEGATIV



↑  
KOLOR ZNAK-LOGOTIP VERTIKALNI NEGATIV



↑  
CRNO-BIJELI ZNAK-LOGOTIP VERTIKALNI NEGATIV



↑  
AKVAREL ZNAK-LOGOTIP VERTIKALNI POZITIV



↑  
KOLOR ZNAK-LOGOTIP VERTIKALNI POZITIV



↑  
CRNO-BIJELI ZNAK-LOGOTIP HVERTIKALNI POZITIV

## Vertikalni odnos znak-logotip HR

### NEGATIV

#### AKVAREL ZNAK-LOGOTIP VERTIKALNI

'Akvel znak-logotip vertikalni' primarni je odnos znak-logotip i preporuča se njegovo korištenje gdje god tehnika reprodukcije i sam dizajn to dopuštaju.

#### KOLOR ZNAK-LOGOTIP VERTIKALNI

'Kolor znak-logotip vertikalni' sekundarni je odnos znak-logotip. Upotrebljava se kada tehnika reprodukcije ne dopušta korištenje 'akvel znak-logotip horizontalni'. (npr. sitotisk, oslikavanje, tampon tisk, katanje, štik itd.)

#### CRNO-BIJELI ZNAK-LOGOTIP VERTIKALNI

'Crno-bijeli znak-logotip vertikalni' tercijarni je odnos znak-logotip. Upotrebljava se isključivo u situacijama kada je nemoguća kolor reprodukcija ili dizajn zahtjeva monokromatski znak-logotip. (npr. gravura, katanje itd.)

### POZITIV

#### AKVAREL ZNAK-LOGOTIP VERTIKALNI

'Akvel znak-logotip vertikalni' primarni je odnos znak-logotip i preporuča se njegovo korištenje gdje god tehnika reprodukcije i sam dizajn to dopuštaju.

#### KOLOR ZNAK-LOGOTIP VERTIKALNI

'Kolor znak-logotip vertikalni' sekundarni je odnos znak-logotip. Upotrebljava se kada tehnika reprodukcije ne dopušta korištenje 'akvel znak-logotip horizontalni'. (npr. sitotisk, oslikavanje, tampon tisk, katanje, štik itd.)

#### CRNO-BIJELI ZNAK-LOGOTIP VERTIKALNI

'Crno-bijeli znak-logotip vertikalni' tercijarni je odnos znak-logotip. Upotrebljava se isključivo u situacijama kada je nemoguća kolor reprodukcija ili dizajn zahtjeva monokromatski znak-logotip. (npr. gravura, žig itd.)

## ZNAK-LOGOTIP VERTIKALNI HR Dimenzije

Dimenzije odnosa znak-logotip određuju se kako bi se stvorio kontinuitet veličina.

**POZITIV**  
Minimalna veličina vertikalnog odnosa znak-logotip je 19 x 21 mm. Vertikalni znak-logotip se ne smije upotrebljavati manji od te dimenzije.

Za znak-logotip koji se upotrebljava u većim dimenzijama od ovdje ilustriranih vrijedi isto progresivno pravilo povećavanja - 300% x, 400% x, 500% x, 600% x, 700% x, 800% x, 900% x...



## ZNAK-LOGOTIP VERTIKALNI HR

# Dimenzije

Dimenzije odnosa znak-logotip određuju se kako bi se stvorio kontinuitet veličina.

### NEGATIV

Minimalna veličina vertikalnog odnosa znak-logotip je 19 x 22 mm. Vertikalni znak-logotip se ne smije upotrebljavati manji od te dimenzije.

Za znak-logotip koji se upotrebljava u većim dimenzijama od ovdje ilustriranih vrijedi isto progresivno pravilo povećavanja - 300% x, 400% x, 500% x, 600% x, 700% x, 800% x, 900% x...

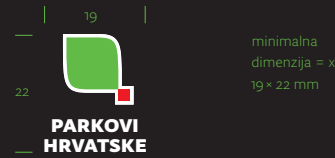

ZNAK-LOGOTIP VERTIKALNI HR

# Minimalni zaštitni prostor

Minimalni zaštitni prostor odnosa znak-logotip je prostor oko znak-logotipa u kojem se ne smiju nalaziti drugi grafički elementi kako se ne bi narušio integritet samog znaka.

Minimalni prostor određen je prema dimenziji 'a' i prikazan je lijevo (točkasti pravokutnik).

Minimalni prostor mjenja se proporcionalno sa dimenzijom samog odnosa znak-logotip.



! mjera 'a' vidljiva je u prikazima u negativu

## ZNAK-LOGOTIP VERTIKALNI HR Apliciranje

### AKROMATSKE KONTINUIRANE PODLOGE

Akromatske kontinuirane podloge su  
ravnomyerne podloge sivog spektra.

Znak-logotip se aplicira u negativu na sve  
akromatske kontinuirane podloge tamnije ili  
jednake 50% crne.

Znak-logotip se aplicira u pozitivu na sve  
akromatske kontinuirane podloge svijetlije od  
50% crne.



C: 0, M: 0, Y: 0, K: 100

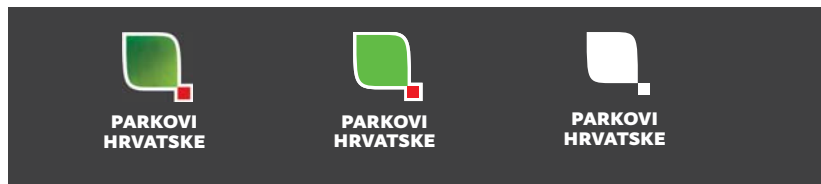

C: 0, M: 0, Y: 0, K: 90



C: 0, M: 0, Y: 0, K: 80



C: 0, M: 0, Y: 0, K: 70



C: 0, M: 0, Y: 0, K: 50



C: 0, M: 0, Y: 0, K: 0

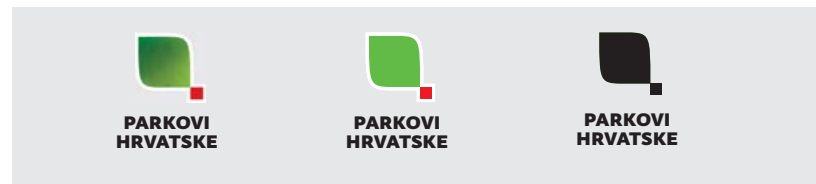

C: 0, M: 0, Y: 0, K: 10



C: 0, M: 0, Y: 0, K: 20



C: 0, M: 0, Y: 0, K: 30



C: 0, M: 0, Y: 0, K: 40



## ZNAK-LOGOTIP VERTIKALNI HR

# Apliciranje

### KROMATSKE KONTINUIRANE PODLOGE

Kromatske kontinuirane podloge su ravnomjerne obojane podloge.

Znak-logotip se aplicira u negativu na sve kromatske kontinuirane podloge tamnije ili jednake 50% crne.

Znak-logotip se aplicira u pozitivu na sve kromatske kontinuirane podloge svjetlije od 50% crne.



c: 100, m: 0, y: 100, k: 20, grayscale ekvivalent 61%



c: 100, m: 0, y: 100, k: 20, grayscale ekvivalent 30%



c: 100, m: 60, y: 0, k: 0, grayscale ekvivalent 65%

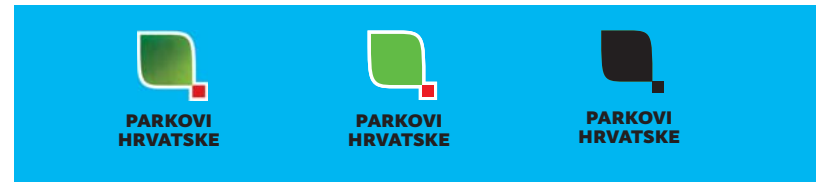

c: 85, m: 0, y: 0, k: 0, grayscale ekvivalent 25%

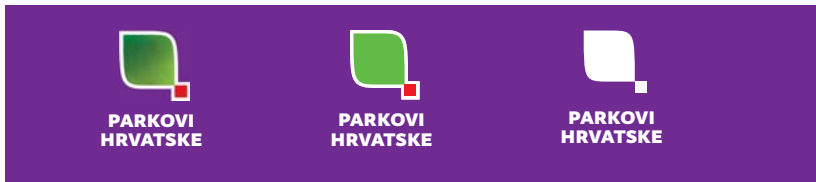

c: 70, m: 100, y: 0, k: 0, grayscale ekvivalent 80%

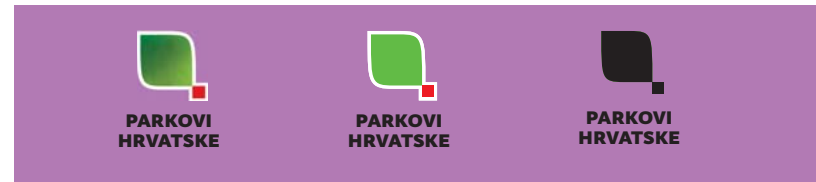

c: 30, m: 60, y: 0, k: 0, grayscale ekvivalent 44%



c: 0, m: 100, y: 100, k: 5, grayscale ekvivalent 50%



c: 0, m: 50, y: 100, k: 0, grayscale ekvivalent 40%

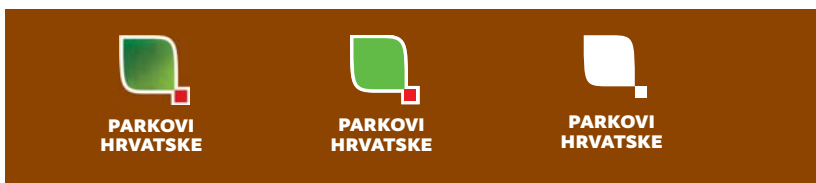

c: 0, m: 65, y: 100, k: 50, grayscale ekvivalent 99%

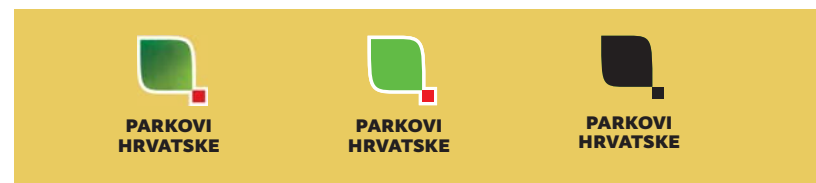

c: 0, m: 10, y: 70, k: 10, grayscale ekvivalent 24%



**PARKOVI  
HRVATSKE**



**PARKOVI  
HRVATSKE**



**PARKOVI  
HRVATSKE**



**PARKOVI  
HRVATSKE**



**PARKOVI  
HRVATSKE**



**PARKOVI  
HRVATSKE**



**PARKOVI  
HRVATSKE**



**PARKOVI  
HRVATSKE**



**PARKOVI  
HRVATSKE**

# Apliciranje

**DISKONTINUIRANE PODLOGE**

Diskontinuirana podloga je fotografska ili grafička podloga koja nije jednobojna.

Znak-logotip se aplicira u negativu) na sve diskontinuirane podloge kojima je srednja svjetlina tamnija ili jednaka 50% crne.

Znak-logotip se aplicira u pozitivu na sve diskontinuirane podloge kojima je srednja svjetlina svjetlija od 50% crne.

Treba izbjegavati aplikaciju znaka-logotipa na diskontinuiranu podlogu koja je toliko heterogena da logotip (i pozitiv i negativ verzija) postaje nečitak.

ZNAK-LOGOTIP VERTIKALNI HR

# Zabrane

**ZABRANJENE APLIKACIJE I MANIPULACIJE**

Odnos znak-logotip se nikada ne smije deformirati (sužavati, izduživati, skraćivati, rotirati...). Odnos znak-logotip strogo je propisan, te se svako njegovo narušavanje smatra deformacijom.

Dozvoljena apliciranja znaka-logotipa na razne pozadine ovise o njegovoj čitkosti i nenaštavanju vizualne komunikativnosti.





**PARKS OF  
CROATIA**

↑  
AKVAREL ZNAK-LOGOTIP VERTIKALNI NEGATIV



**PARKS OF  
CROATIA**

↑  
KOLOR ZNAK-LOGOTIP VERTIKALNI NEGATIV



**PARKS OF  
CROATIA**

↑  
CRNO-BIJELI ZNAK-LOGOTIP VERTIKALNI NEGATIV



**PARKS OF  
CROATIA**

↑  
AKVAREL ZNAK-LOGOTIP VERTIKALNI POZITIV



**PARKS OF  
CROATIA**

↑  
KOLOR ZNAK-LOGOTIP VERTIKALNI POZITIV



**PARKS OF  
CROATIA**

↑  
CRNO-BIJELI ZNAK-LOGOTIP HVERTIKALNI POZITIV

## Vertikalni odnos znak- logotip ENG

### NEGATIV

#### AKVAREL ZNAK-LOGOTIP VERTIKALNI

'Akvel znak-logotip vertikalni' primarni je odnos znak-logotip i preporuča se njegovo korištenje gdje god tehnika reprodukcije i sam dizajn to dopuštaju.

#### KOLOR ZNAK-LOGOTIP VERTIKALNI

'Kolor znak-logotip vertikalni' sekundarni je odnos znak-logotip. Upotrebljava se kada tehnika reprodukcije ne dopušta korištenje 'akvel znak-logotip horizontalni'. (npr. sitotisak, oslikavanje, tampon tisak, katiranje, štik itd.)

#### CRNO-BIJELI ZNAK-LOGOTIP VERTIKALNI

'Crno-bijeli znak-logotip vertikalni' tercijarni je odnos znak-logotip. Upotrebljava se isključivo u situacijama kada je nemoguća kolor reprodukcija ili dizajn zahtjeva monokromatski znak-logotip. (npr. gravura, katiranje itd.)

### POZITIV

#### AKVAREL ZNAK-LOGOTIP VERTIKALNI

'Akvel znak-logotip vertikalni' primarni je odnos znak-logotip i preporuča se njegovo korištenje gdje god tehnika reprodukcije i sam dizajn to dopuštaju.

#### KOLOR ZNAK-LOGOTIP VERTIKALNI

'Kolor znak-logotip vertikalni' sekundarni je odnos znak-logotip. Upotrebljava se kada tehnika reprodukcije ne dopušta korištenje 'akvel znak-logotip horizontalni'. (npr. sitotisak, oslikavanje, tampon tisak, katiranje, štik itd.)

#### CRNO-BIJELI ZNAK-LOGOTIP VERTIKALNI

'Crno-bijeli znak-logotip vertikalni' tercijarni je odnos znak-logotip. Upotrebljava se isključivo u situacijama kada je nemoguća kolor reprodukcija ili dizajn zahtjeva monokromatski znak-logotip. (npr. gravura, žig itd.)

ZNAK-LOGOTIP VERTIKALNI ENG

# Dimenzije

Dimenzije odnosa znak-logotip određuju se kako bi se stvorio kontinuitet veličina.

**POZITIV**

Minimalna veličina vertikalnog odnosa znak-logotip je 18 x 21 mm. Vertikalni znak-logotip se ne smije upotrebljavati manji od te dimenzije.

Za znak-logotip koji se upotrebljava u većim dimenzijama od ovdje ilustriranih vrijedi isto progresivno pravilo povećavanja - 300% x, 400% x, 500% x, 600% x, 700% x, 800% x, 900% x...



ZNAK-LOGOTIP VERTIKALNI ENG

# Dimenzije

Dimenzije odnosa znak-logotip određuju se kako bi se stvorio kontinuitet veličina.

**NEGATIV**

Minimalna veličina vertikalnog odnosa znak-logotip je 18 x 22 mm. Vertikalni znak-logotip se ne smije upotrebljavati manji od te dimenzije.

Za znak-logotip koji se upotrebljava u većim dimenzijama od ovdje ilustriranih vrijedi isto progresivno pravilo povećavanja - 300% x, 400% x, 500% x, 600% x, 700% x, 800% x, 900% x...



ZNAK-LOGOTIP VERTIKALNI ENG

# Minimalni zaštitni prostor

Minimalni zaštitni prostor odnosa znak-logotip je prostor oko znak-logotipa u kojem se ne smiju nalaziti drugi grafički elementi kako se ne bi narušio integritet samog znaka.

Minimalni prostor određen je prema dimenziji 'a' i prikazan je lijevo (točkasti pravokutnik).

Minimalni prostor mjenja se proporcionalno sa dimenzijom samog odnosa znak-logotip.

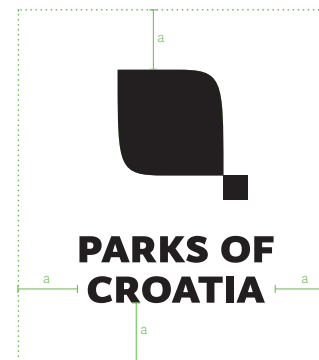
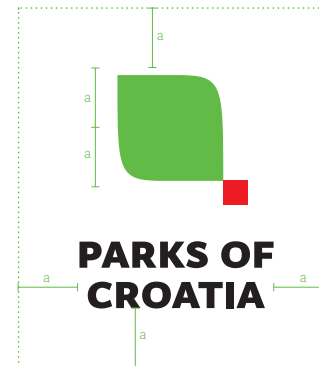

! mjera 'a' vidljiva je u prikazima u negativu

## ZNAK-LOGOTIP VERTIKALNI ENG Apliciranje

### AKROMATSKE KONTINUIRANE PODLOGE

Akromatske kontinuirane podloge su  
ravnomyjerne podloge sivog spektra.

Znak-logotip se aplicira u negativu na sve  
akromatske kontinuirane podloge tamnije ili  
jednake 50% crne.

Znak-logotip se aplicira u pozitivu na sve  
akromatske kontinuirane podloge svjetlije od  
50% crne.



C: 0, M: 0, Y: 0, K: 100

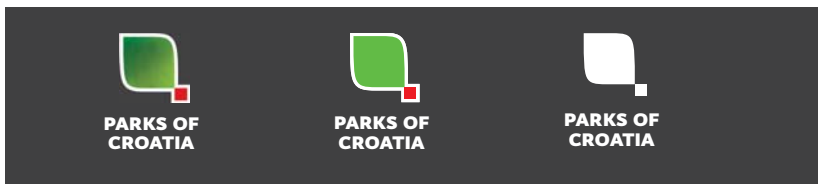

C: 0, M: 0, Y: 0, K: 90



C: 0, M: 0, Y: 0, K: 80



C: 0, M: 0, Y: 0, K: 70



C: 0, M: 0, Y: 0, K: 50



C: 0, M: 0, Y: 0, K: 0



C: 0, M: 0, Y: 0, K: 10



C: 0, M: 0, Y: 0, K: 20



C: 0, M: 0, Y: 0, K: 30



C: 0, M: 0, Y: 0, K: 40



## ZNAK-LOGOTIP VERTIKALNI ENG Apliciranje

**KROMATSKE KONTINUIRANE PODLOGE**  
Kromatske kontinuirane podloge su  
ravnomyerje obojane podloge.

Znak-logotip se aplicira u negativu na sve  
kromatske kontinuirane podloge tamnije ili  
jednake 50% crne.

Znak-logotip se aplicira u pozitivu na sve  
kromatske kontinuirane podloge svjetlije od  
50% crne.



C: 100, M: 0, Y: 100, K: 20, grayscale ekvivalent 61%



C: 100, M: 0, Y: 100, K: 20, grayscale ekvivalent 30%



C: 100, M: 60, Y: 0, K: 0, grayscale ekvivalent 65%



C: 85, M: 0, Y: 0, K: 0, grayscale ekvivalent 25%

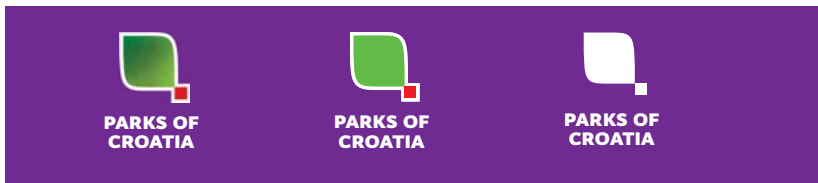

C: 70, M: 100, Y: 0, K: 0, grayscale ekvivalent 80%

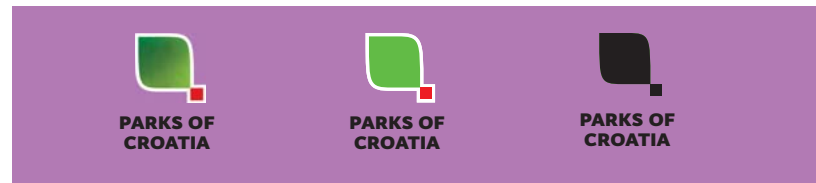

C: 30, M: 60, Y: 0, K: 0, grayscale ekvivalent 44%



C: 0, M: 100, Y: 100, K: 5, grayscale ekvivalent 50%



C: 0, M: 50, Y: 100, K: 0, grayscale ekvivalent 40%



C: 0, M: 65, Y: 100, K: 50, grayscale ekvivalent 99%



C: 0, M: 10, Y: 70, K: 10, grayscale ekvivalent 24%



**PARKS OF  
CROATIA**



**PARKS OF  
CROATIA**



**PARKS OF  
CROATIA**



**PARKS OF  
CROATIA**



**PARKS OF  
CROATIA**



**PARKS OF  
CROATIA**



**PARKS OF  
CROATIA**



**PARKS OF  
CROATIA**



**PARKS OF  
CROATIA**

**PARKOVI HRVATSKE**  
PRIRUČNIK OSNOVNIH GRAFIČKIH STANDARDA

**ZNAK-LOGOTIP VERTIKALNI ENG**

## Apliciranje

### DISKONTINUIRANE PODLOGE

Diskontinuirana podloga je fotografska ili grafička podloga koja nije jednobojna.

Znak-logotip se aplicira u negativu) na sve diskontinuirane podloge kojima je srednja svjetlina tamnija ili jednaka 50% crne.

Znak-logotip se aplicira u pozitivu na sve diskontinuirane podloge kojima je srednja svjetlina svjetlija od 50% crne.

Treba izbjegavati aplikaciju znaka-logotipa na diskontinuiranu podlogu koja je toliko heterogena da logotip (i pozitiv i negativ verzija) postaje nečitak.

ZNAK-LOGOTIP VERTIKALNI ENG

# Zabrane

**ZABRANJENE APLIKACIJE I MANIPULACIJE**

Odnos znak-logotip se nikada ne smije deformirati (sužavati, izduživati, skraćivati, rotirati...). Odnos znak-logotip strogo je propisan, te se svako njegovo narušavanje smatra deformacijom.

Dozvoljena apliciranja znaka-logotipa na razne pozadine ovise o njegovoj čitkosti i nenarušavanju vizualne komunikativnosti.





↑  
AKVAREL ZNAK-LOGOTIP VERTIKALNI NEGATIV



↑  
KOLOR ZNAK-LOGOTIP VERTIKALNI NEGATIV



↑  
CRNO-BIJELI ZNAK-LOGOTIP VERTIKALNI NEGATIV



↑  
AKVAREL ZNAK-LOGOTIP VERTIKALNI POZITIV



↑  
KOLOR ZNAK-LOGOTIP VERTIKALNI POZITIV



↑  
CRNO-BIJELI ZNAK-LOGOTIP HVERTIKALNI POZITIV

## Vertikalni odnos znak-logotip HR/ENG

### NEGATIV

#### AKVAREL ZNAK-LOGOTIP VERTIKALNI

'Akvarel znak-logotip vertikalni' primarni je odnos znak-logotip i preporuča se njegovo korištenje gdje god tehnika reprodukcije i sam dizajn to dopuštaju.

#### KOLOR ZNAK-LOGOTIP VERTIKALNI

'Kolor znak-logotip vertikalni' sekundarni je odnos znak-logotip. Upotrebljava se kada tehnika reprodukcije ne dopušta korištenje 'akvarel znak-logotip horizontalni'. (npr. sitotisak, oslikavanje, tampon tisak, katanje, štik itd.)

#### CRNO-BIJELI ZNAK-LOGOTIP VERTIKALNI

'Crno-bijeli znak-logotip vertikalni' tercijarni je odnos znak-logotip. Upotrebljava se isključivo u situacijama kada je nemoguća kolor reprodukcija ili dizajn zahtjeva monokromatski znak-logotip. (npr. gravura, katanje itd.)

### POZITIV

#### AKVAREL ZNAK-LOGOTIP VERTIKALNI

'Akvarel znak-logotip vertikalni' primarni je odnos znak-logotip i preporuča se njegovo korištenje gdje god tehnika reprodukcije i sam dizajn to dopuštaju.

#### KOLOR ZNAK-LOGOTIP VERTIKALNI

'Kolor znak-logotip vertikalni' sekundarni je odnos znak-logotip. Upotrebljava se kada tehnika reprodukcije ne dopušta korištenje 'akvarel znak-logotip horizontalni'. (npr. sitotisak, oslikavanje, tampon tisak, katanje, štik itd.)

#### CRNO-BIJELI ZNAK-LOGOTIP VERTIKALNI

'Crno-bijeli znak-logotip vertikalni' tercijarni je odnos znak-logotip. Upotrebljava se isključivo u situacijama kada je nemoguća kolor reprodukcija ili dizajn zahtjeva monokromatski znak-logotip. (npr. gravura, žig itd.)

ZNAK-LOGOTIP VERTIKALNI HR/ENG

# Dimenzije

Dimenzije odnosa znak-logotip određuju se kako bi se stvorio kontinuitet veličina.

**POZITIV**

Minimalna veličina vertikalnog odnosa znak-logotip je 19 x 23 mm. Vertikalni znak-logotip se ne smije upotrebljavati manji od te dimenzije.

Za znak-logotip koji se upotrebljava u većim dimenzijama od ovdje ilustriranih vrijedi isto progresivno pravilo povećavanja - 300% x, 400% x, 500% x, 600% x, 700% x, 800% x, 900% x...



minimalna  
dimenzija = x  
19 x 23 mm



minimalna  
dimenzija = x  
19 x 23 mm



minimalna  
dimenzija = x  
19 x 23 mm



150% x



150% x



150% x



200% x



200% x



200% x

ZNAK-LOGOTIP VERTIKALNI HR/ENG

# Dimenzije

Dimenzije odnosa znak-logotip određuju se kako bi se stvorio kontinuitet veličina.

**NEGATIV**

Minimalna veličina vertikalnog odnosa znak-logotip je 19 x 24 mm. Vertikalni znak-logotip se ne smije upotrebljavati manji od te dimenzije.

Za znak-logotip koji se upotrebljava u većim dimenzijama od ovdje ilustriranih vrijedi isto progresivno pravilo povećavanja - 300% x, 400% x, 500% x, 600% x, 700% x, 800% x, 900% x...

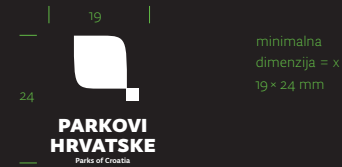

ZNAK-LOGOTIP VERTIKALNI HR/ENG

# Minimalni zaštitni prostor

Minimalni zaštitni prostor odnosa znak-logotip je prostor oko znak-logotipa u kojem se ne smiju nalaziti drugi grafički elementi kako se ne bi narušio integritet samog znaka.

Minimalni prostor određen je prema dimenziji 'a' i prikazan je lijevo (točkasti pravokutnik).

Minimalni prostor mjenja se proporcionalno sa dimenzijom samog odnosa znak-logotip.



! mjera 'a' vidljiva je u prikazima u negativu

## ZNAK-LOGOTIP VERTIKALNI HR/ENG Apliciranje

### AKROMATSKE KONTINUIRANE PODLOGE

Akromatske kontinuirane podloge su  
ravnomyerne podloge sivog spektra.

Znak-logotip se aplicira u negativu na sve  
akromatske kontinuirane podloge tamnije ili  
jednake 50% crne.

Znak-logotip se aplicira u pozitivu na sve  
akromatske kontinuirane podloge svjetlije od  
50% crne.



C: 0, M: 0, Y: 0, K: 100



C: 0, M: 0, Y: 0, K: 90



C: 0, M: 0, Y: 0, K: 80



C: 0, M: 0, Y: 0, K: 70

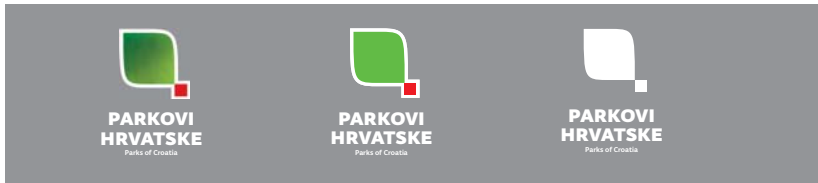

C: 0, M: 0, Y: 0, K: 50



C: 0, M: 0, Y: 0, K: 0

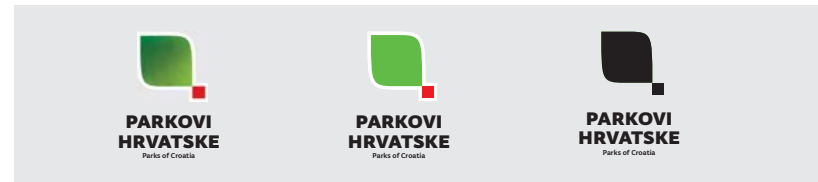

C: 0, M: 0, Y: 0, K: 10



C: 0, M: 0, Y: 0, K: 20

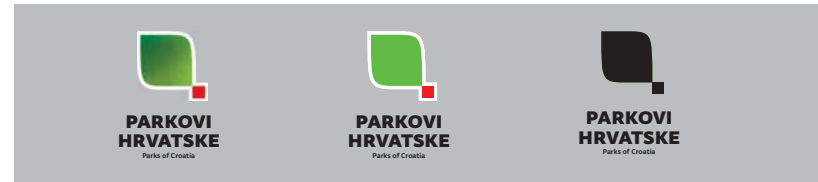

C: 0, M: 0, Y: 0, K: 30



C: 0, M: 0, Y: 0, K: 40



# Apliciranje

## KROMATSKE KONTINUIRANE PODLOGE

Kromatske kontinuirane podloge su  
ravnomyjerne obojane podloge.

Znak-logotip se aplicira u negativu na sve  
kromatske kontinuirane podloge tamnije ili  
jednake 50% crne.

Znak-logotip se aplicira u pozitivu na sve  
kromatske kontinuirane podloge svjetlije od  
50% crne.



C: 100, M: 0, Y: 100, K: 20, grayscale ekvivalent 61%



C: 100, M: 0, Y: 100, K: 20, grayscale ekvivalent 30%



C: 100, M: 60, Y: 0, K: 0, grayscale ekvivalent 65%

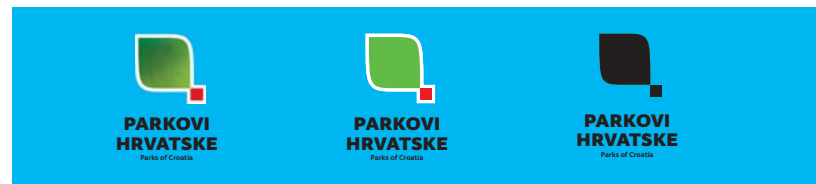

C: 85, M: 0, Y: 0, K: 0, grayscale ekvivalent 25%

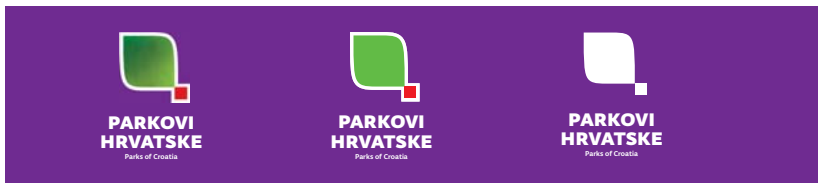

C: 70, M: 100, Y: 0, K: 0, grayscale ekvivalent 80%

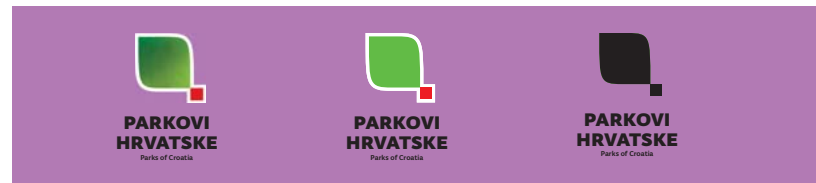

C: 30, M: 60, Y: 0, K: 0, grayscale ekvivalent 44%



C: 0, M: 100, Y: 100, K: 5, grayscale ekvivalent 50%

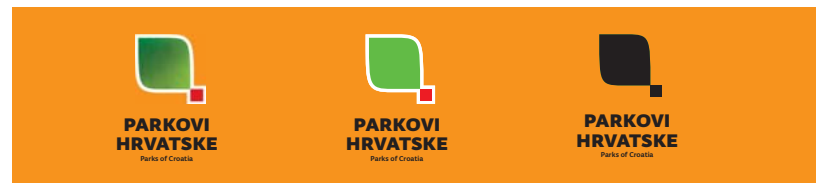

C: 0, M: 50, Y: 100, K: 0, grayscale ekvivalent 40%

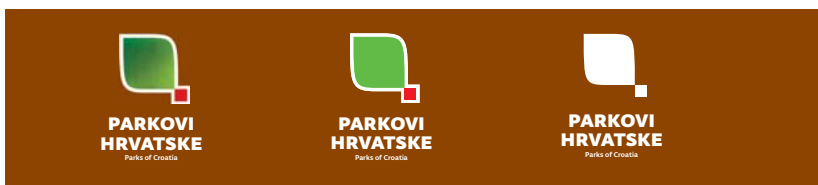

C: 0, M: 65, Y: 100, K: 50, grayscale ekvivalent 99%



C: 0, M: 10, Y: 70, K: 10, grayscale ekvivalent 24%



**PARKOVI HRVATSKE**  
PRIRUČNIK OSNOVNIH GRAFIČKIH STANDARDA

**ZNAK-LOGOTIP VERTIKALNI HR/ENG**

# Apliciranje

## DISKONTINUIRANE PODLOGE

Diskontinuirana podloga je fotografska ili grafička podloga koja nije jednobojna.

Znak-logotip se aplicira u negativu) na sve diskontinuirane podloge kojima je srednja svjetlina tamnija ili jednaka 50% crne.

Znak-logotip se aplicira u pozitivu na sve diskontinuirane podloge kojima je srednja svjetlina svjetlija od 50% crne.

Treba izbjegavati aplikaciju znaka-logotipa na diskontinuiranu podlogu koja je toliko heterogena da logotip (i pozitiv i negativ verzija) postaje nečitak.



ZNAK-LOGOTIP HORIZONTALNI HR/ENG

# Zabrane

ZABRANJENE APLIKACIJE I MANIPULACIJE

Odnos znak-logotip se nikada ne smije deformirati (sužavati, izduživati, skraćivati, rotirati...). Odnos znak-logotip strogo je propisan, te se svako njegovo narušavanje smatra deformacijom.

Dozvoljena apliciranja znaka-logotipa na razne pozadine ovise o njegovoj čitkosti i nenarušavanju vizualne komunikativnosti.



## Tipografija vizualnog identiteta

Tipografija je jedan od osnovnih elemenata vizualnog identiteta (uz znak, logotip i boju).

Typonine Sans Pro je jedina preporučena tipografija ovog vizualnog identiteta. Typonine ima to rezova i zadovoljava gotovo sve potrebe.

Drugu tipografiju dopušteno je koristiti isključivo ako nije moguće koristiti Typonine Sans Pro (slučajevi materijala na kojima se koriste druga pisma - ćirilica, grčko pismo, arapsko pismo i sl. ili kada je druga tipografija u službi ilustracije)

Aa Bb

Typonine Sans Pro Light

Aa Bb

Typonine Sans Pro Normal

Aa Bb

Typonine Sans Pro Text

*Aa Bb*

Typonine Sans Pro Light Italic

*Aa Bb*

Typonine Sans Pro Normal Italic

*Aa Bb*

Typonine Sans Pro Text Italic

**Aa Bb**

Typonine Sans Pro Medium

**Aa Bb**

Typonine Sans Pro Bold

***Aa Bb***

Typonine Sans Pro Medium Italic

***Aa Bb***

Typonine Sans Pro Bold Italic

## Boja vizualnog identiteta

Boja je jedan od osnovnih elemenata vizualnog identiteta (uz znak, logotip i tipografiju).

Radi jačanja prepoznatljivosti vizualnog identiteta preporuča se upotreba identitetskih boja gdje god je moguće.



PANTONE 360

RAL 6018

C: 65%, M: 0%, Y: 100%, K: 0%

R: 97, G: 194, B: 80

HTML: 61C250



PANTONE 348

RAL 6029

C: 100%, M: 0%, Y: 100%, K: 20%

R: 0, G: 133, B: 66

HTML: 009848



PANTONE 186

RAL 3020

C: 0%, M: 100%, Y: 100%, K: 0%

R: 224, G: 0, B: 52

HTML: E00034



PANTONE BLACK

RAL 9011

C: 0%, M: 0%, Y: 0%, K: 100%

R: 0, G: 0, B: 0

HTML: 000000

# Odnosi znaka 'Parkovi Hrvatske' i znaka pojediniog parka

Na idućih nekoliko stranica definiraju se odnosi znaka 'Parkovi Hrvatske' sa znakom pojedinog parka. Taj sustav odnosi se na materijale na kojima se na istoj stranici/površini pojavljuju oba znaka (npr. plakat, web stranica, letak, ulaznica itd.) Na materijalima koji, po svojoj logici, zahtjevaju drugačiji tretman znakova (npr. majice, ikona mobilne aplikacije, šalica...) ne mora se držati tog sustava.

Osnovna logika koje se drži ovaj sustav je da se znakovi parka i 'Parkova Hrvatske' koriste u istoj veličini i istom obliku (akvarel/akvarel, horizontalni odnos/horizontalni odnos) te da je znak parka na primarnoj poziciji, a znak Parkova Hrvatske u sekundarnoj poziciji. Primarna i sekundarna pozicija određena je po našoj zapadnjačkoj logici čitanja - s lijeva na desno i odozgo prema dolje. Tako je u horizontalnom odnosu znakova lijeva pozicija primarna, a u vertikalnom odnosu gornja.

Za potrebe ovog priručnika ilustracije su izvedene sa znakom parka prirode Medvednice, ali svaki park koristi svoj znak na isti način kako je ilustrirano i opisano u priručniku.

## Horizontalan odnos znakova

Znak parka i 'Parkova Hrvatske' mogu se pozicionirati tako da su poravnati vertikalno ili horizontalno.

U situaciji kada su poravnati horizontalno (kao u ilustraciji lijevo) postoje dva pravila:

1. uvijek koristiti iste tipove znaka (npr. oba akvarel, pozitivna ili oba kolor negativ)
2. odnosi veličina znakova moraju biti ujednačeni kao na ilustraciji lijevo.



## Horizontalan odnos

Znak-logotip parka i 'Parkova Hrvatske' mogu se pozicionirati tako da su poravnati verikalno ili horizontalno.

U situaciji kada su poravnati horizontalno (kao u ilustraciji lijevo) postoje dva pravila:

1. uvijek koristiti iste tipove znak-logotip (npr. oba akvarel, horizontalna ili oba kolor negativ horizontalna)
2. odnosi veličina znak-logotipa moraju biti ujednačeni kao na ilustraciji lijevo.

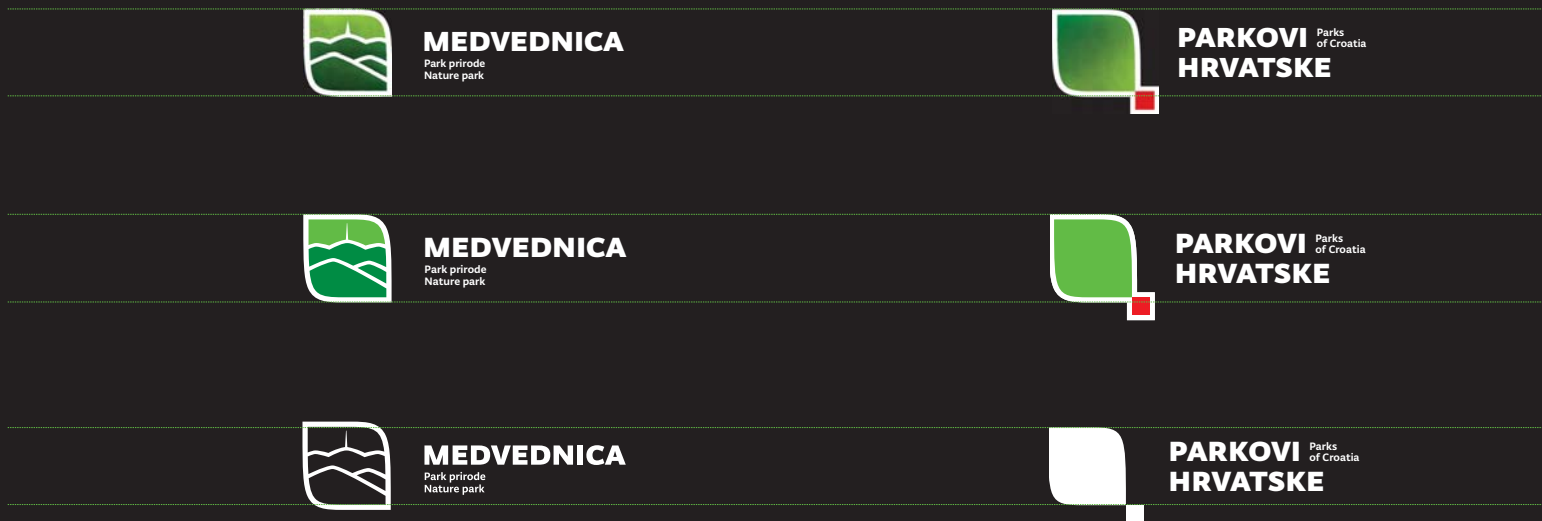
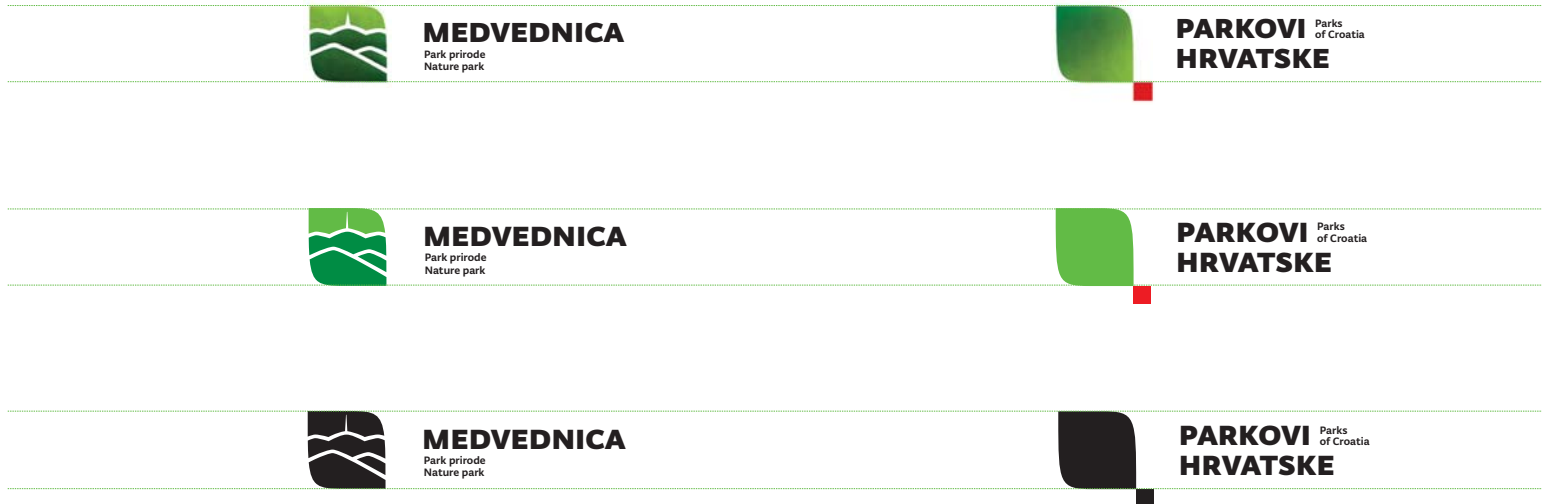



## Horizontalan odnos

Znak-logotip parka i 'Parkova Hrvatske' mogu se pozicionirati tako da su poravnati verikalno ili horizontalno.

U situaciji kada su poravnati horizontalno (kao u ilustraciji lijevo) postoje dva pravila:

1. uvijek koristiti iste tipove znak-logotip (npr. oba akvarel, vertikalna ili oba kolor negativ vertikalna)
2. odnosi veličina znak-logotipa moraju biti ujednačeni kao na ilustraciji lijevo.



**MEDVEDNICA**  
Park prirode • Nature park



**PARKOVI HRVATSKE**  
Parks of Croatia



**MEDVEDNICA**  
Park prirode • Nature park



**PARKOVI HRVATSKE**  
Parks of Croatia



**MEDVEDNICA**  
Park prirode • Nature park



**PARKOVI HRVATSKE**  
Parks of Croatia



**MEDVEDNICA**  
Park prirode • Nature park



**PARKOVI HRVATSKE**  
Parks of Croatia



**MEDVEDNICA**  
Park prirode • Nature park



**PARKOVI HRVATSKE**  
Parks of Croatia



**MEDVEDNICA**  
Park prirode • Nature park



**PARKOVI HRVATSKE**  
Parks of Croatia

## Vertikalan odnos znakova

Znak parka i 'Parkova Hrvatske' mogu se pozicionirati tako da su poravnati vertikalno ili horizontalno.

U situaciji kada su poravnati vertikalno (kao u ilustraciji lijevo) postoje dva pravila:

1. uvijek koristiti iste tipove znakova (npr. oba akvarel ili oba kolor negativ)
2. odnosi veličina znakova moraju biti ujednačeni kao na ilustraciji lijevo.

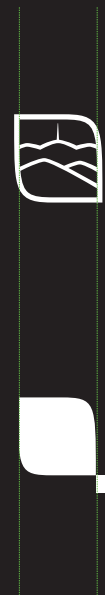
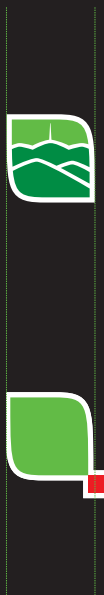
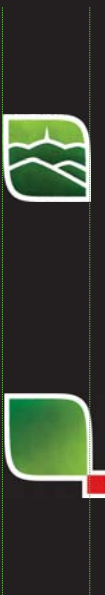

## Vertikalan odnos

Znak-logotip parka i 'Parkova Hrvatske' mogu se pozicionirati tako da su poravnati verikalno ili horizontalno.

U situaciji kada su poravnati vertikalno (kao u ilustraciji lijevo) postoje dva pravila:

1. uvijek koristiti iste tipove znak-logotip (npr. oba akvarel, horizontalna ili oba kolor negativ horizontalna)
2. odnosi veličina znak-logotipa moraju biti ujednačeni kao na ilustraciji lijevo.



## Vertikalan odnos

Znak-logotip parka i 'Parkova Hrvatske' mogu se pozicionirati tako da su poravnati vertikalno ili horizontalno.

U situaciji kada su poravnati vertikalno (kao u ilustraciji lijevo) postoje dva pravila:

1. uvijek koristiti iste tipove znak-logotip (npr. oba akvarel, vertikalna ili oba kolor negativ vertikalna)
2. odnosi veličina znak-logotipa moraju biti ujednačeni kao na ilustraciji lijevo.

